

 **MICROCYBER**

M0313

Modbus to FF built-in module

**User Manual**

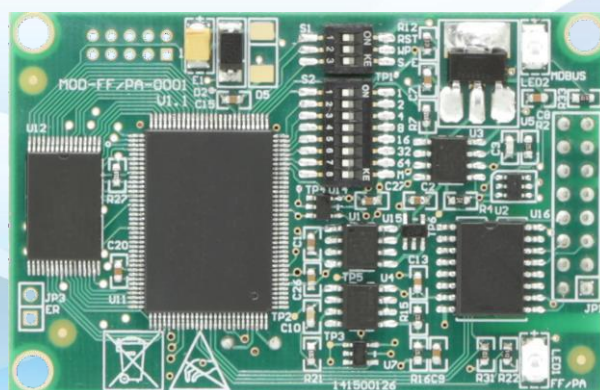



## Caution

1. Please don't take off/install module at random.
2. Please check if the power of module meets the power request in the User Manual.

## Version:

V2.0

## Disclaimer of Liability

We have reviewed the contents of this publication to ensure consistency with the hardware and software described. Since variance cannot be precluded entirely, we cannot guarantee full consistency. However, the information in this publication is reviewed regularly and any necessary corrections are included in subsequent editions.

## Microcyber Corporation 2016

The technical data may change at any time.





## Company Introduction

Microcyber Corporation, established as a high-tech enterprise by the Shenyang Institute of Automation Chinese Academy of Sciences, mainly engages in advanced industrial control systems, equipments, instruments and chips for industrial process automation control solutions in the research, development, production and application. Microcyber undertakes a number of national scientific and technical key task and -863II project, and has Liaoning Province networked control systems engineering research center. The company successfully developed the FF H1 fieldbus protocol stack which is number one to be approved internationally in China, and the Industrial Ethernet Protocol(HSE) which is number one to be approved in China, and the domestic first fieldbus instrument which has a function of national-level intrinsically safe explosion--proof and safety barrier. Also Microcyber participated in the drafting of the domestic first Ethernet-based industrial automation protocol standards (Ethernet for Plant Automation, EPA). As a result, serial products are composed of configuration, control software, embedded software, control system, instrument chip to the OEM board, and make Microcyber be an industrial automation products provider in full range, and also further Microcyber's leading position in the field of fieldbus technology.

Microcyber is the FF member, the HART member and the Profibus National Organization (PNO) member.

Microcyber passes the Authentication of ISO 9001 Quality System, and has an outstanding innovative R&D team, plentiful practical experiences of design of the Automatic engineering, a leading product series, a huge market network, a strict quality management system and an excellent enterprise culture. All these further a solid foundation of entrepreneurship and sustainable development for Microcyber.

Microcyber Inc. is looking forward to the long-term smooth and close cooperation with you.



## Table of Contents

Section 1 Summary.....	1
1.1.1 Features.....	1
1.1.2 Same Size.....	1
1.1.3 Same Interface.....	1
1.1.4 Easy to Upgrade.....	1
1.1.5 Easy to configure.....	1
1.2 Product Development Process.....	2
1.3 Outer Size Diagram.....	3
1.4 Structure Diagram.....	3
Section 2. Installation.....	4
2.1 External Interface.....	4
2.1.1 Communication interface JP1.....	4
2.1.2 Configuration of DIP Switch.....	4
2.2 Installation of Module.....	5
Section 3. Working Principle.....	6
Section 4. Configuration of module.....	7
4.1 Topologic connection.....	7
4.2 Introduction for Function.....	8
4.3 Parameter Specification for Modbus Transducer Block.....	8
4.3.1 BAD_STATUS Parameter Description.....	9
4.3.2 ERR_LOOK_RESULT Parameter Description.....	9
4.4 Communication Parameter for Modbus Transducer Block.....	9
4.5 Example for configuration of Modbus Slave station.....	11
4.6 Reason of unsuccessfully Switch Transducer Block to Auto Status.....	15
5 Maintenance.....	21
Appendix 1 Parameter List for Modbus Transducer Block.....	23
Appendix 2 Common parameter list.....	25
Appendix 3 Model Selection Table for M0313 Module.....	26

## Section 1 Summary

Modbus-FF built-in module realizes the conversion function from MODBUS Protocol to Foundation Fieldbus F1 Protocol. It is one of the Microcyber M-series modules, which have features of same size, same interface, easy to upgrade and easy to configure. It is an ideal choice for user to develop fieldbus devices. As Modbus master station, M0313 Modbus to FF module communicates with Modbus-RTU device via TTL interface, and it can convert the data of Modbus-RTU device to FF device variable output. M0313 Modbus to FF module is shown in Figure 1.1:

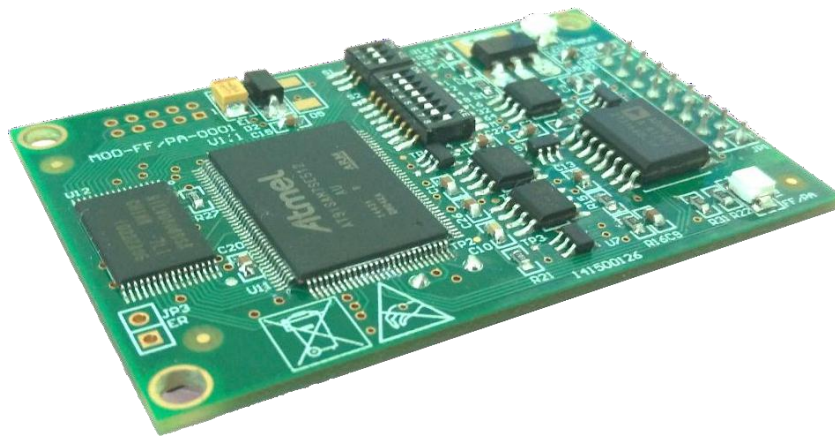

Figure 1.1 M0313 Modbus to FF Built-in Module

### 1.1.1 Features

### 1.1.2 Same Size

The Microcyber M series built-in modules have the same size: 65mm (length) \* 42mm (width) .

### 1.1.3 Same Interface

The connector of Microcyber M series built-in modules is 2.54 pitch 16 pin, function of them are compatible.

### 1.1.4 Easy to Upgrade

Please replace the different kind of Microcyber M series modules to realize the different protocols of devices.

### 1.1.5 Easy to configure

Please use the special tool provided by Microcyber Corporation for configuration, it is easy to operate .



## 1.2 Product Development Process

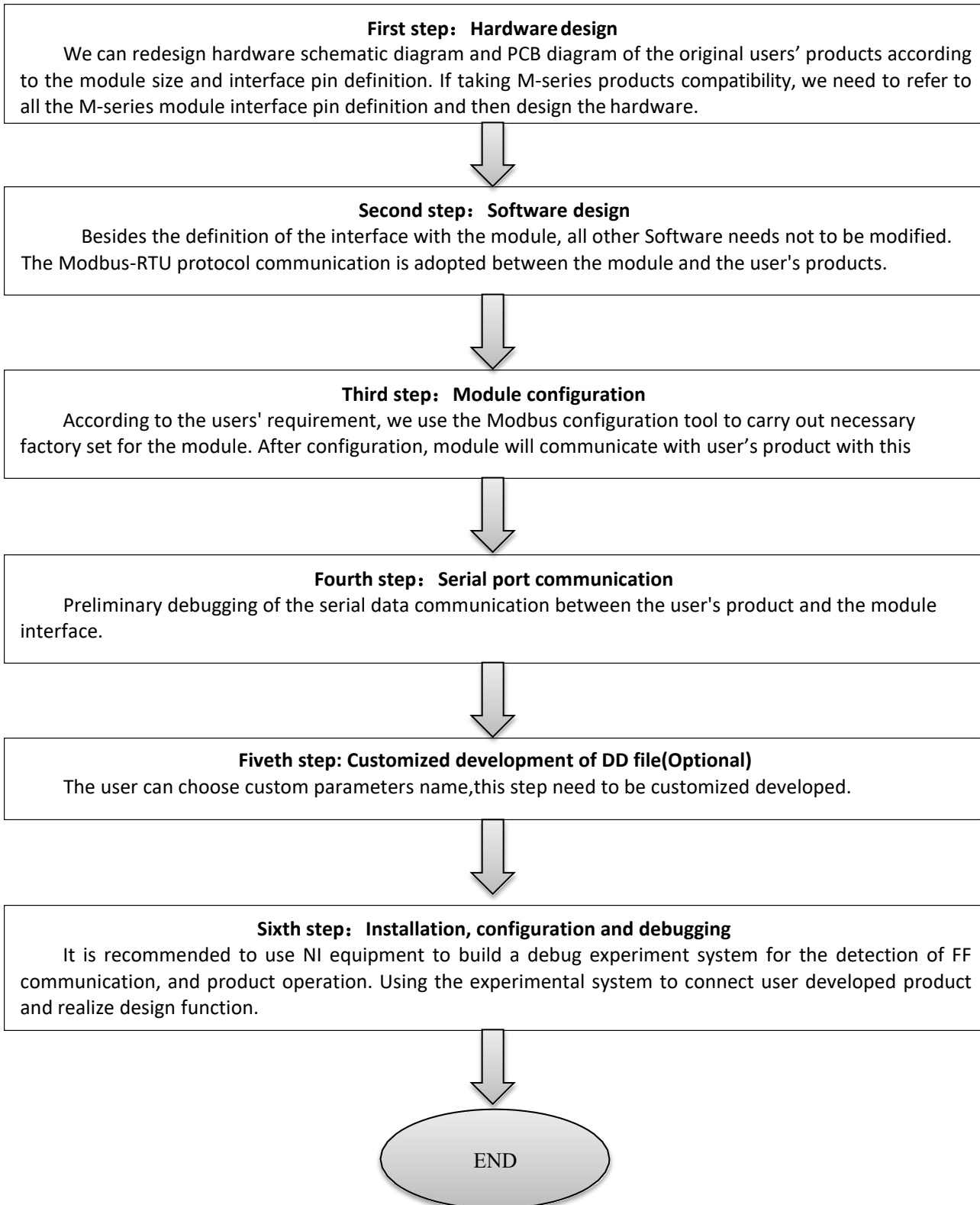

### 1.3 Outer Size Diagram

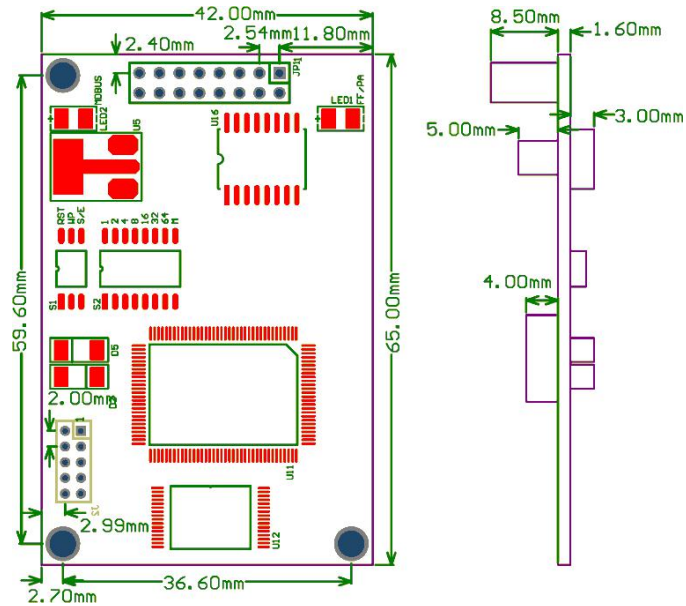

Figure 1.2 Outer size of built-in module(Unit: mm)

### 1.4 Structure Diagram

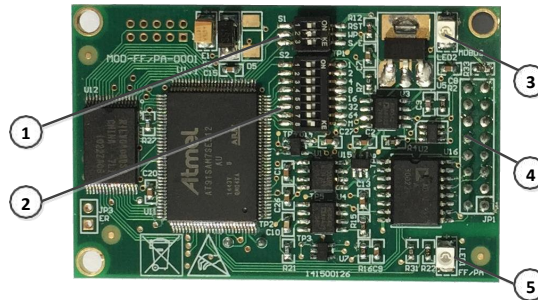

Figure 1.3 Whole structure of built-in module

1	DIP switch S1	DIP switch S2	LED2 Modbus communication light
4	Communication interface	LED1 FF communication light	

## Section 2. Installation

### 2.1 External Interface

M0313 Modbus to FF built-in modul's terminal distribution and meaning is shown as figure 2.1:

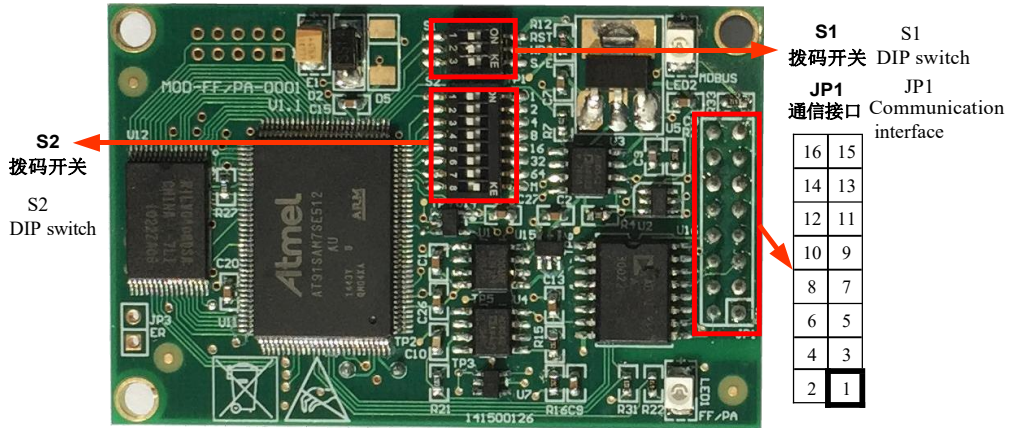

Figure 2.1 M0313 Modbus to FF built-in modul's terminal distribution and meaning

#### 2.1.1 Communication interface JP1

JP1 Communication interfac's meaning is shown as below:

Pin	I/O	Name	Description	Pin	I/O	Name	Description
1	I	VCC_IS	The signal isolation power supply, provided by baseboard	2	I	GND_IS	The signal isolated power ground, provided by baseboard.
3	I	/RES	CPU Reset, low active	4	I/O	NC	Reserved
5	O	TXD	CPU TXD	6	O	RTS-485	RS-485 control port*
7	I/O	NC	Reserved	8	I	RXD	CPU RXD
9	O	NC	Reserved	10	I/O	Status	Communication indicating light
11	I/O	BUS+	Bus Power Supply+	12	I/O	BUS-	Bus Power Supply-
13	I/O	NC	Reserved	14	I/O	NC	Reserved
15	I/O	NC	Reserved	16	I/O	NC	Reserved

\*: It is used for coonection with RS-485 communication chip.

#### 2.1.2 Configuration of DIP Switch

There is a 3-position DIP switch S1 and a 8-position DIP switch S2 for M0313 Modbus to FF built-in module, shown as figure Figure 2. 1

The description fo DIP switch S1 is shown as below:

No	Name	Description
1	RST	Reset, reset device data to factory original. Power off the device at first, and made the switch at ON, and then power on the device, the device shall be reseted to factory original.
2	WP	Write protection, all the write operation for FF communication module shall be refused, which avoid data modification at random.





3	S/E	Simulation switch,used for -simulation functionll.
---	-----	--

The description fo DIP switch S2 is shown as below:

No	Name	Description
1	1	Standing off
2	2	Standing off
3	4	Standing off
4	8	Standing off
5	16	Standing off
6	32	Standing off
7	64	Standing off
8	M	Set the work mode, configuration mode(ON)and normal work mode(OFF)

## 2.2 Installation of Module

There are three  $\Phi 3$  location hole in the module.The module can be fixedly installed in the user’s board with three hexagonal prism.

## Section 3. Working Principle

M0313 Modbus to FF built-in module is a module supporting Modbus and FF protocol. As FF device, it can communicate with Modbus devices, read Modbus data to FF device by simply configuration, and transfer data to control system through FF bus. System Wiring Diagram of Modbus to FF built-in module is shown in Figure 3.1:

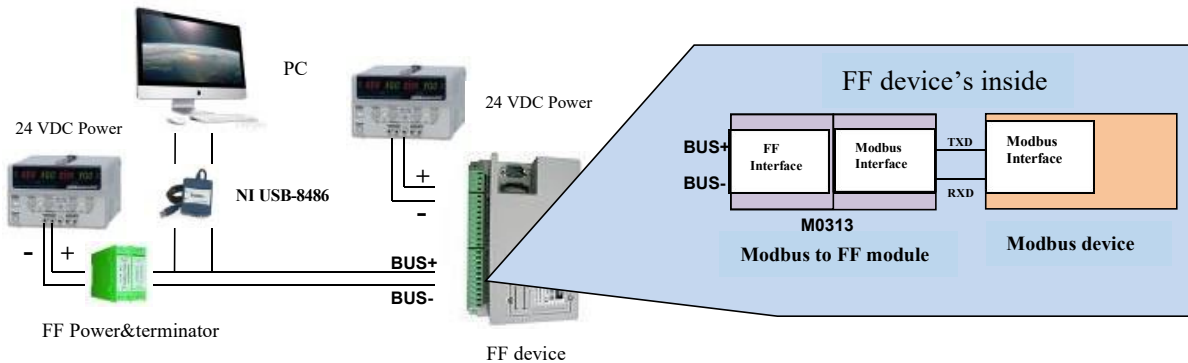

Figure 3.1 System Wiring Diagram of M0313 Modbus to FF built-in module

M0313 Modbus to FF built-in module support 1 Modbus slave device, 8 groups of analog input and discrete input output parameters, totally 32 channels provided. It configures Modbus device's data into transducer block's parameters via Modbus register, and provides data support for FF system via channels between variables and AI, AO, DI and DO function blocks. Principle Diagram for Modbus to FF built-in module is shown in Figure 3.2:

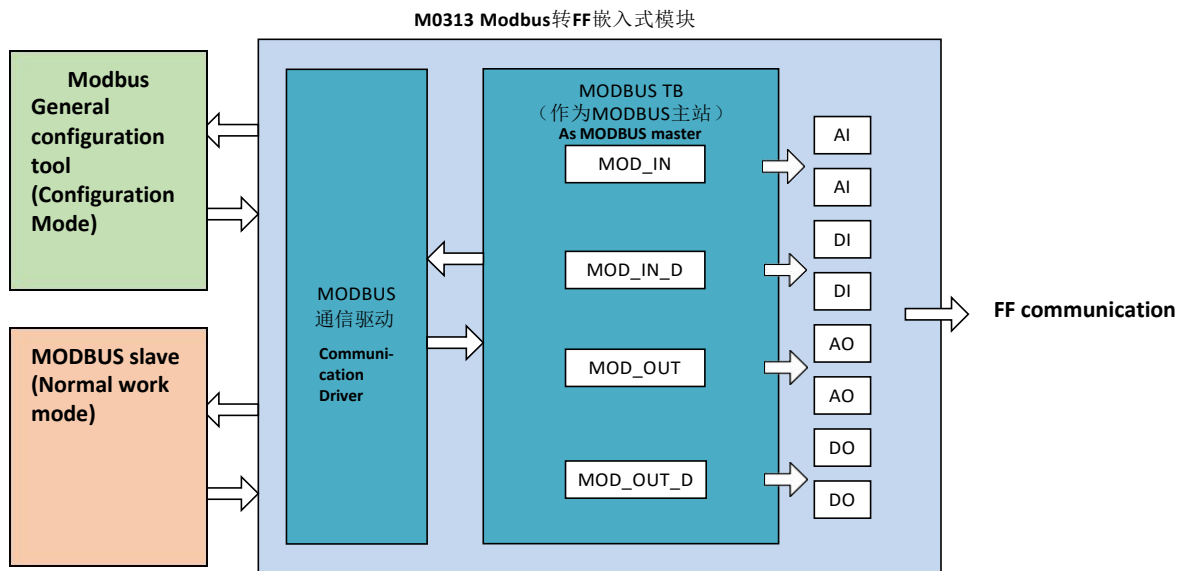

Figure 3.2 M0313 Principle Diagram for Modbus to FF built-in module

## Section 4. Configuration of module

### 4.1 Topologic connection

FF device support many net topologies shown as Figure 4.1. The bus connection of FF instrument is shown in Figure 4.2, in order to ensure the bus signal quality, the terminal matching resistances should be connected to the 2 ends of the bus. The bus maximum length is 1900m, with a repeater, the length can be extended to 10 kilometers.

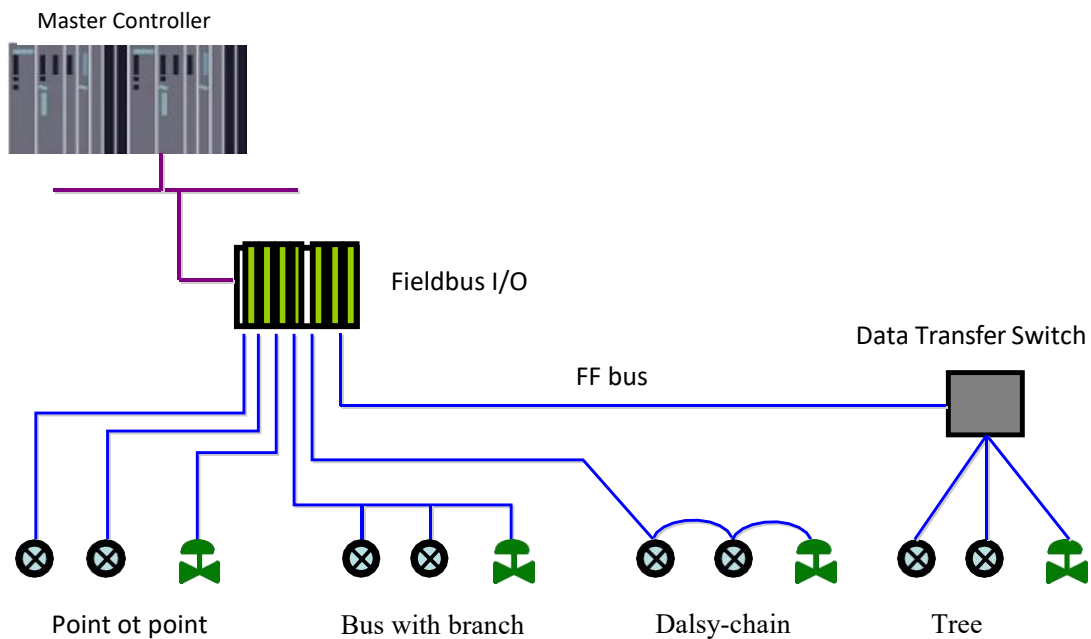

Figure 4.1 Topology of FF Bus

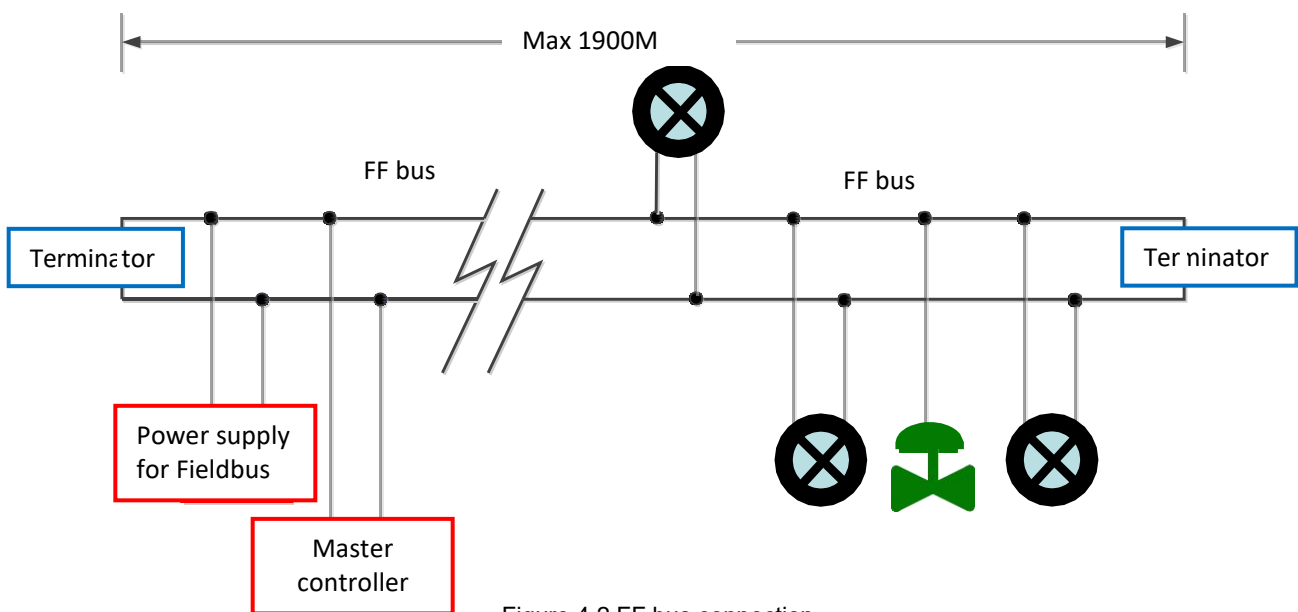

Figure 4.2 FF bus connection



## 4.2 Introduction for Function

Default configuration of Modbus to FF built-in module has 1 RES function block,4 for each AI,AO,DI,DO,PID function block and Modbus transducer block(Modbus\_TB)complying to FF specifications.AI,AO,DI,DO respectively supports 8 channels(CHANNEL),channel is corresponding to analog/discrete input and output parameters of Modbus transducer block.

Function Block name	Description
Resource (RES)	Resource block is used to describe the device identity in the field,such as device name,manufacture,serial number.There is no input or output parameter in the resource block.Generally,there is noly one resource block for each device.
Modbus_TB(MTB)	Configure Modbus communication parameters via transducer block, such as baud rate, stop bit, communication overtime, etc., Modbus communication configuration parameter.
Analog Input (AI)	Analog input function block is used to achieve transducer block input data and transfer to other function blocks, has the function of range conversion, square root, cut mantissa, etc.
Analog Output (AO)	Analog output function block is used to transfer output data to transducer block, then to operate physical device.
Discrete Input (DI)	Discrete input function block, achieve transducer block input data and transfer to other functions blocks.
Discrete Output (DO)	Discrete output function block is used to transfer discrete output data to transducer block, then to operate physical device.
Proportional Integral Derivative (PID)	PID function block has the function of PID control and setting point adjustment, process value(PV) filtering and alarm, output tracking, etc.

## 4.3 Parameter Specification for ModbusTransducer Block

Including NI-Configurator software as an example of how to configure Modbus transducer block.Shown as Figure 4.3, the MODBUS transducer block provides 8 couples of Analog input output and 8 couples of digital input output parameters,which are process parameters,user can choose the configuration for at least 1 analog input and 1 digital input. In addition, the MODBUS transducer block also provide 10 couples of 32-bit floating points,10 couples of 16-bit floating points and 10 couples of 8-bit floating points,1 couple of 32-bit string parameter,can be used for configuration parameter.All above parameters configured by Modbus general configuration tool,but not FF configuration software.

Note: The eighth position M of DIP switch S2 should be in -OFFlstate,i.e. under normal work mode.



图 4.3 Modbus 变换块

### 4.3.1 BAD\_STATUS Parameter Description

If the communication failed, the related bit will be set as 1, otherwise, it will be 0.

BIT	PARAMETER	BIT	PARAMETER	BIT	PARAMETER	BIT	PARAMETER
0	MOD_IN1	8	MOD_OUT1	16	MOD_IN_D1	24	MOD_OUT_D 1
1	MOD_IN2	9	MOD_OUT 2	17	MOD_IN_D 2	25	MOD_OUT_D 2
2	MOD_IN3	10	MOD_OUT 3	18	MOD_IN_D 3	26	MOD_OUT_D 3
3	MOD_IN4	11	MOD_OUT 4	19	MOD_IN_D 4	27	MOD_OUT_D 4
4	MOD_IN5	12	MOD_OUT 5	20	MOD_IN_D 5	28	MOD_OUT_D 5
5	MOD_IN6	13	MOD_OUT 6	21	MOD_IN_D 6	29	MOD_OUT_D 6
6	MOD_IN7	14	MOD_OUT 7	22	MOD_IN_D 7	30	MOD_OUT_D 7
7	MOD_IN8	15	MOD_OUT 8	23	MOD_IN_D 8	31	MOD_OUT_D 8

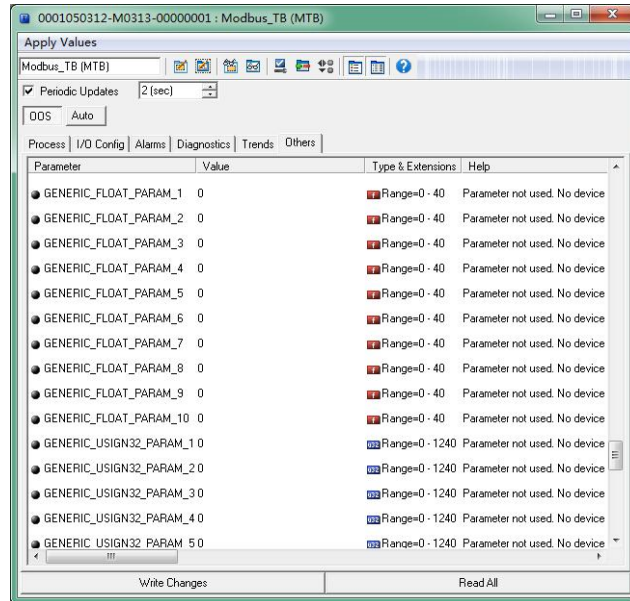
### 4.3.2 ERR\_LOOK\_RESULT Parameter Description

ERR\_LOOK\_RESULT, data inquiry function for input output parameter negative response. User is able to inquiry about every input output response value, reading ERR\_LOOK\_RESULT parameter will receive the communication response data of this parameter.(Please using Modbus general configuration tool to inquiry parameters). ERR\_LOOK\_RESULT, 0 means there is no failure. 0x01 – 0x0B is standard negative data, and 0xFF means slave station communication is in failure.

Value	Parameter Description	Value	Parameter Description
0x00	OK	0x06	Slave Device Busy
0x01	Illegal Function	0x08	Memory Parity Error
0x02	Illegal Data Address	0x0A	Gateway Path Unavailable
0x03	Illegal Data Value	0x0B	Gateway Target Device Failed To Response
0x04	Slave Device Failure	0xFE	Function Code Mismatch
0x05	Acknowledge	0xFF	Communication Failure

## 4.4 Communication Parameter for Modbus Transducer Block

The user is able to configure the Modbus communication parameter, such as common parameter, analog input, analog output, digital input, digital output, floating point data, data USIGN32, data USIGN16, data USIGN8 and data Octet etc.

Modbus configuration tool for common parameter is shown as Figure 4.4, more details please see the Appendix 3,

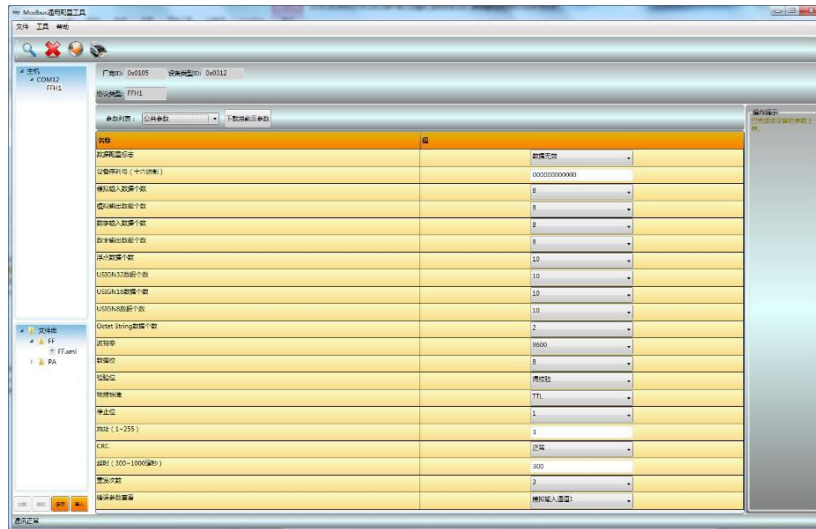

Figure 4.4 Modbus Modbus configuration tool

In addition to the common parameter, all the data can be configured as read-write, data format, register address and function code, users can flexibly configure as required. Due to the different parameter type support different Modbus function code, so the selection of corresponding data format is needed after choosing the function code, not optional data format is automatically set to gray by software, user selection is not allowed, shown as Figure 4.5:

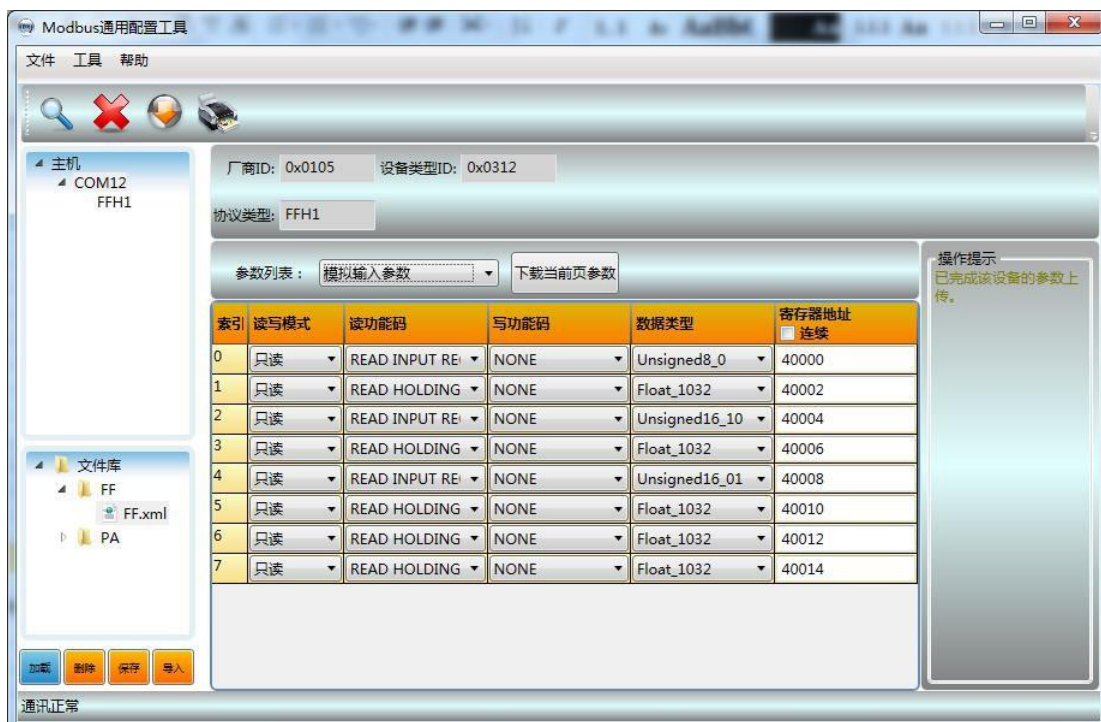

Figure 4.5 Parameter Configuration

Both separately download parameter in data interface and together download via Download button are available after configuration.



Note:For more detailed applying method of Modbus general configuration tool,please refer to software help file. Note: The eighth position M of DIP switch S2 should be in -ON|| state,i.e. under configuration mode.

### 4.5 Example for configuration of Modbus Slave station

Communication parameter of User’s Modbus slave station is shown as below:

NO.	Parameter	Value
1	Baud Rate	9600 bps
2	Data Bits	8
3	Parity	Even-parity Check
4	Physical Standard	TTL
5	Stop Bits	1
6	Address	1
7	CRC	Normal
8	Timeout	300ms
9	Number of Retry	3

User’s Modbus slave station support function code 03(Read Holding Registers)and function code 16(Preset Multiple Registers),the register of device parameter is allocated as shown below:

Register Address (decimalism)	Data Format	Registers Definition
4112	Float Inverse	Representation of instantaneous flow float
4114	Float Inverse	Representation of instantaneous velocity float
4116	Float Inverse	Representation of flow percentage float representation(the battery powered type is preserved)
4118	Float Inverse	Representation Fluid conductance ratio float
4120	Long Inverse	Integer part of positive accumulation value
4122	Float Inverse	Decimal part of positive accumulation value
4124	Long Inverse	Integer part of negative accumulation value negative
4126	Float Inverse	Decimal part of negative accumulation value
4128	Unsigned short	Unit of instantaneous flow
4129	Unsigned short	Unit of accumulation total quantity

Step 1.

Please check if the eighth position M of DIP switch S2 is in -ON|| state.If not,please switch it to -ON|| state.

Step 2.

Open the Modbus general configuration tool software, set up the serial port, and scan the equipment online,as shown below:

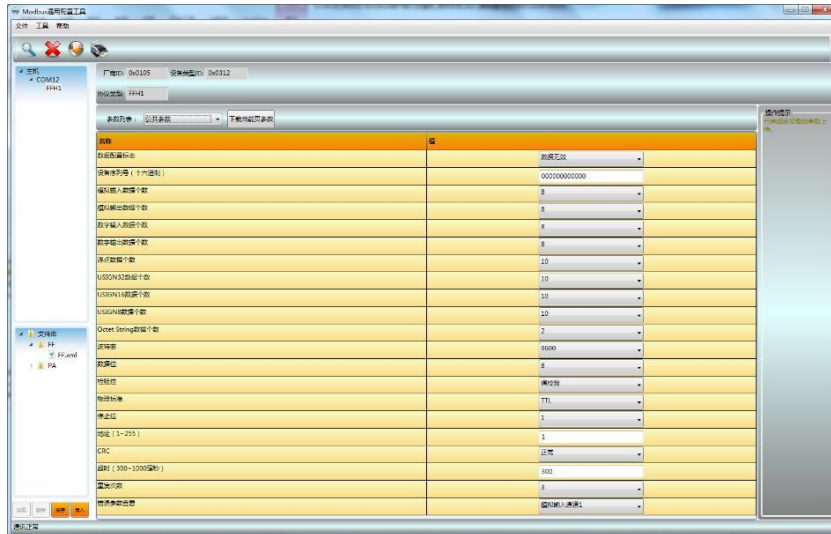

Figure 4.5 Scanning equipment

Step 3.

Set parameter in the public parameter table according to the parameter of users Modbus slave station, as shown below:

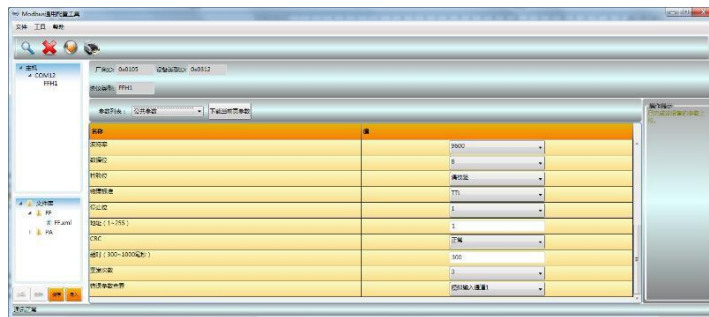

Figure 4.6 Configuration of communication parameter

Step 4.

Modify public parameter according to the users device parameter list, the analog input data is 8, USIGN16 parameter is 2, the others is 0, as shown below:

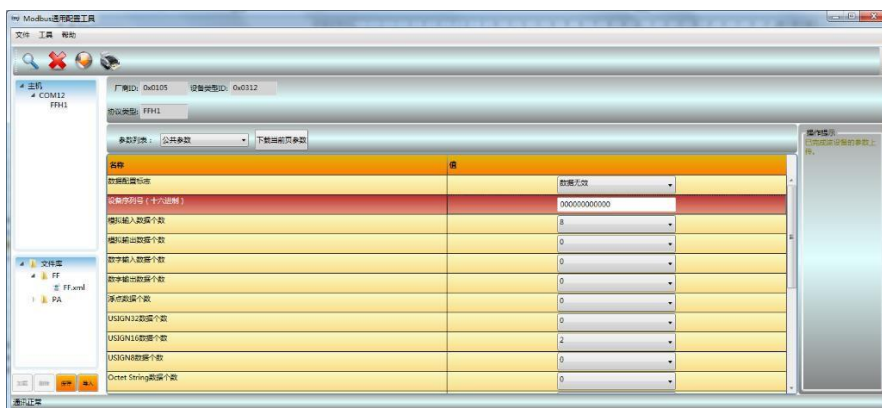

Figure 4.7 Configuration of other public parameter



### Step 5.

Open the options page of analog input parameter, firstly choose the needed function code, secondly choose the data type of analog input data, finally enter the register address .

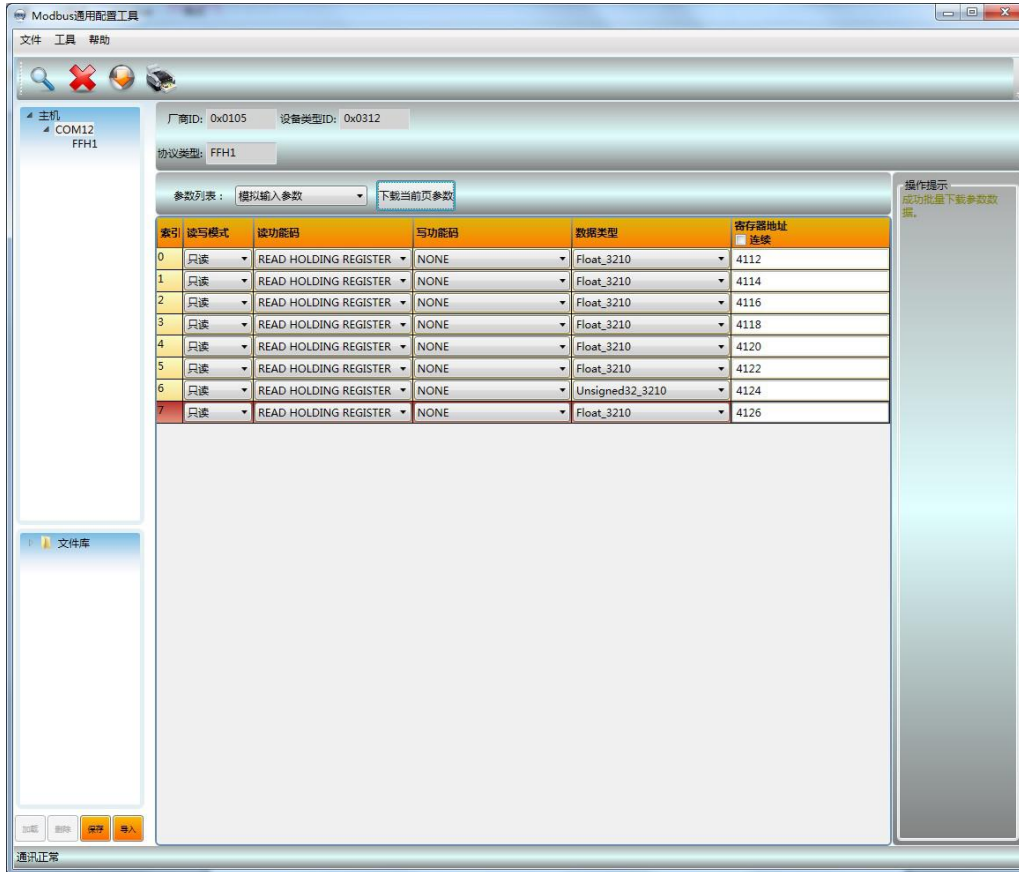

Figure 4.8 Configuration of analog input parameter

*Note: The register address is a actual address, if the register address presented by users Modbus slave device is addressing, then need to minus 1 to get the actual address.*

### Step 6.

USIGN16 data parameter options page, firstly choose the read-write mode of USIGN16 data, secondly choose the data type and using function code, finally enter the register address, as shown below:

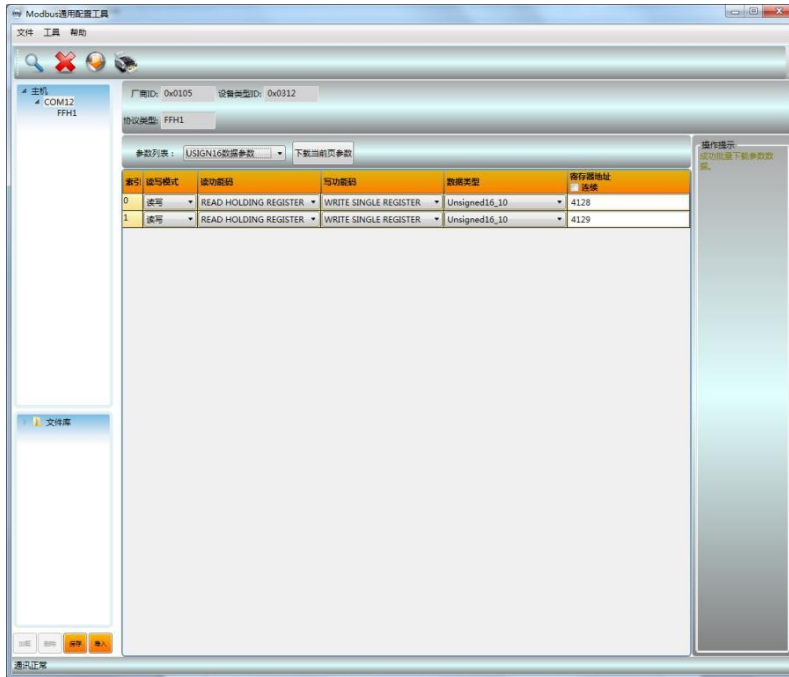

Figure 4.9 USIGN16 data parameters configuration

### Step 7

Return to the public parameters options page, modify the mark of data configuration to -Data Valid, click on the bottom of -BULK DOWNLOAD, write the configuration data to the device, as shown below:

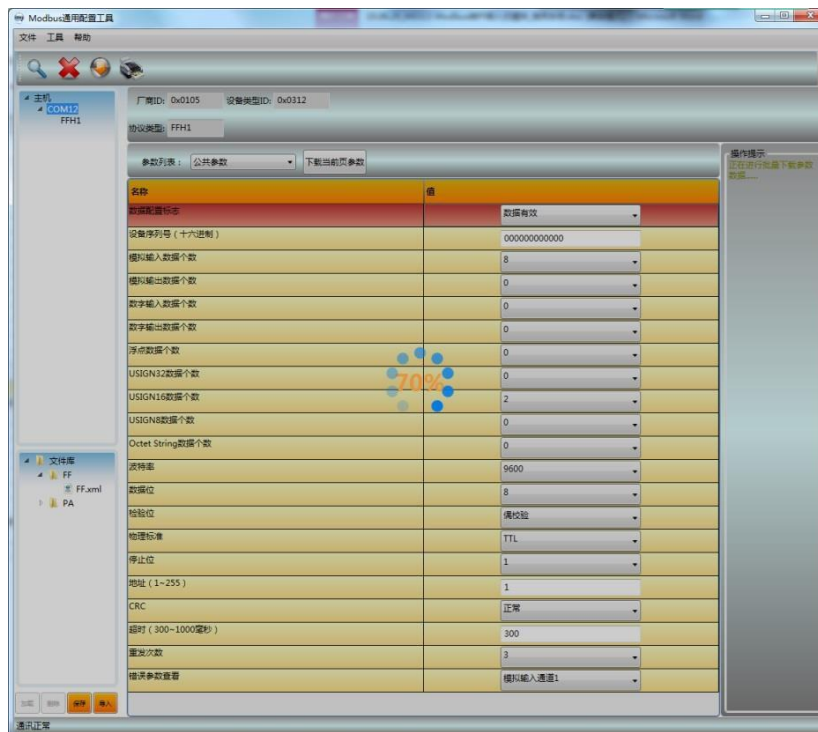

Figure 4.10 Enable data is valid and download parameter

### Step 8.

Switch the eighth position M of DIP switch S2 to the -OFF state, using the NI configuration software to connect the device into FF network, to check the transducer blocks parameter, as shown below:

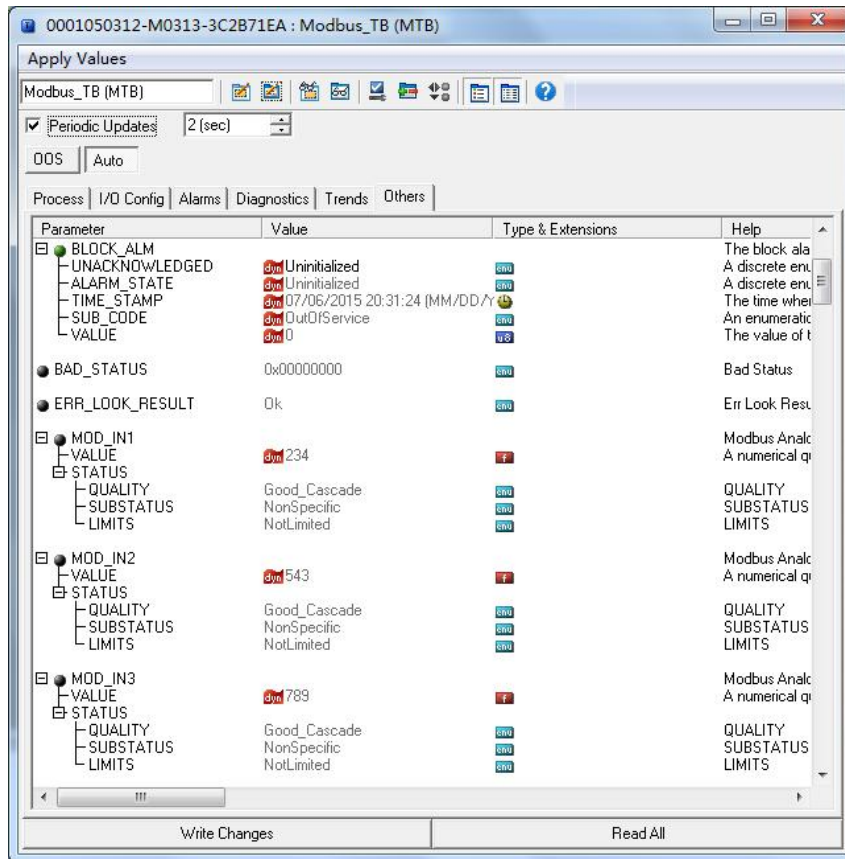

Figure 4.11 Detection of Modbus slave devices data via FF configuration software

By applying above steps, you can make the FF device work normally. The Modbus slave devices data are transferred to AI, AO, DI and DO function blocks via transducer block parameter.

If the function block is not in the Auto status, then the data will not be updated. Please refer to the solving method in the section 4.6.

## 4.6 Reason of unsuccessfully Switch Transducer Block to Auto Status

There are multiple reasons why transducer block can't be turned into Auto status. You can figure these problems out by checking the state of eighth position M of DIP switch S2, and parameter BLOCK\_ERR, XD\_ERROR, BAD\_STATUS and ERR\_LOOK\_RESULT of transducer block.

### Situation 1

After the device is power on, if the parameter values of XD\_ERROR function block is "Configuration error", the ERR\_LOOK\_RESULT is -OK, the BAD\_STATUS is "0x00000000". Please check if the eighth

position M of DIP switch S2 is in -OFF|| state.If not,please switch it to -OFF|| state.(Under normal work mode)

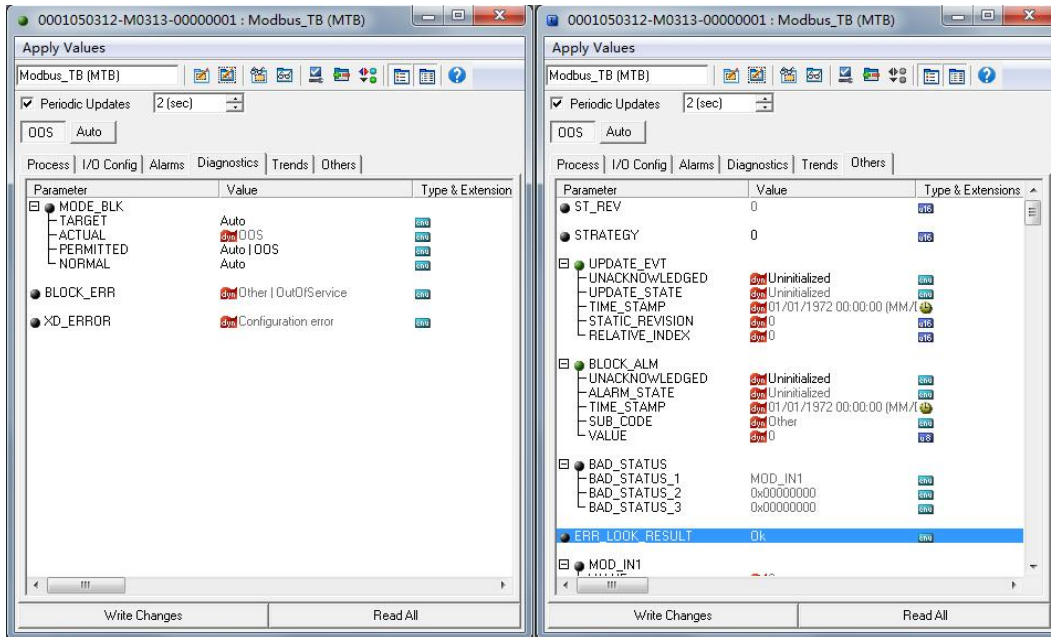

Figure 4.12 OOS situation 1 of transducer block

### Situation 2

After the device is power on, if the parameter values of XD\_ERROR function block is“Configuration error||, the ERR\_LOOK\_RESULT is “Comm Failure||,the BAD\_STATUS for example is “MOD\_IN1||,it indicates that there is configuration problem with communication parameter.Please check the situation of configuration of communication parameter via Modbus general configuration tool.

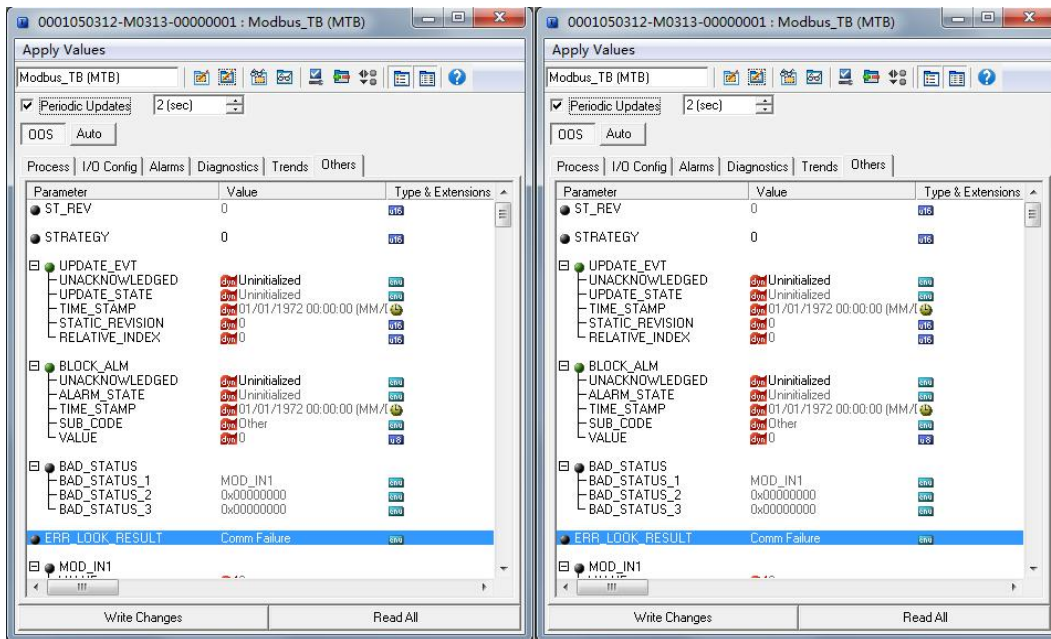

Figure 4.13 OOS situation 2 of transducer block

### Situation 3

After the device is power on, if the parameter values of XD\_ERROR function block is “Configuration error”, the ERR\_LOOK\_RESULT is “Function Code Mismatch”, the BAD\_STATUS for example is “MOD\_IN1”, it indicates that there is configuration problem with function code of parameter. Please check the situation of function code’s configuration of parameter via Modbus general configuration tool.

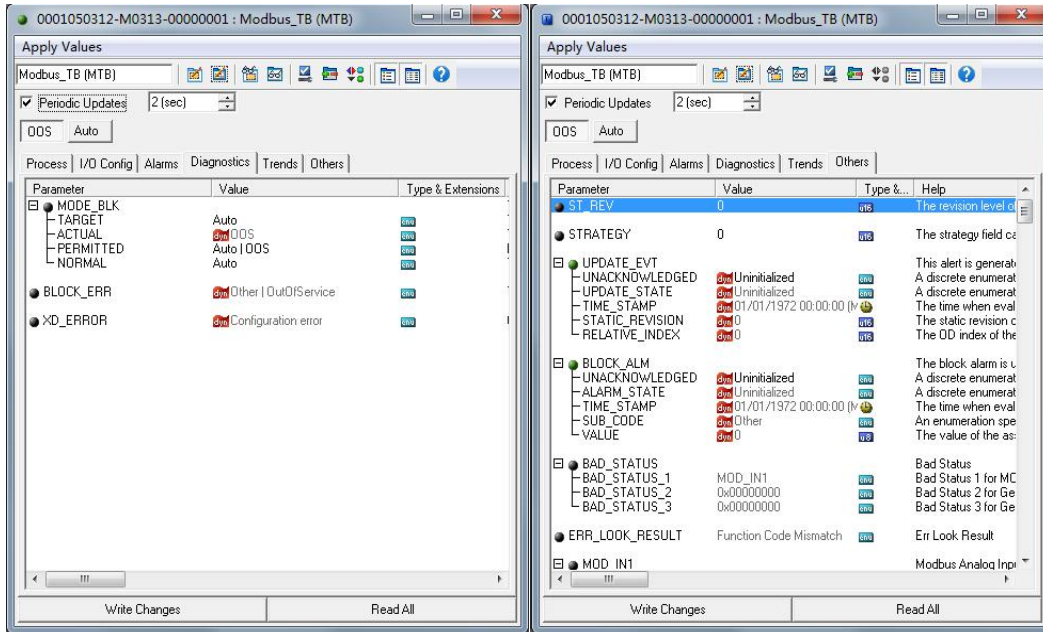

Figure 4.14 OOS situation 3 of transducer block

### Situation 4

After the device is power on, if the parameter values of XD\_ERROR function block is—Configuration error, the ERR\_LOOK\_RESULT is—Data Type Mismatch, the BAD\_STATUS for example is -MOD\_IN\_D1, it indicates that there is configuration problem with data type of parameter. Please check the situation of data type’s configuration of parameter via Modbus general configuration tool.

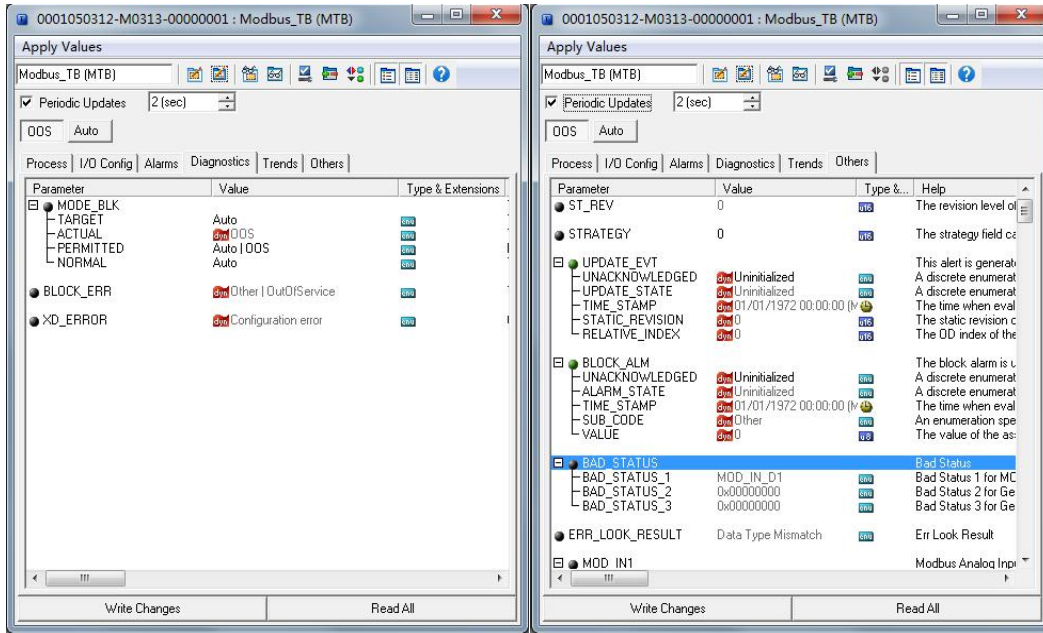

Figure 4.15 OOS situation 4 of transducer block

### Situation 5

After the device is power on, if the parameter values of XD\_ERROR function block is—Data Integrity Error, the ERR\_LOOK\_RESULT is—Comm Failure, the BAD\_STATUS for example is -MOD\_IN1, it indicates that there is interrupt signal problem in the process of normal communication. Please check the device connection.

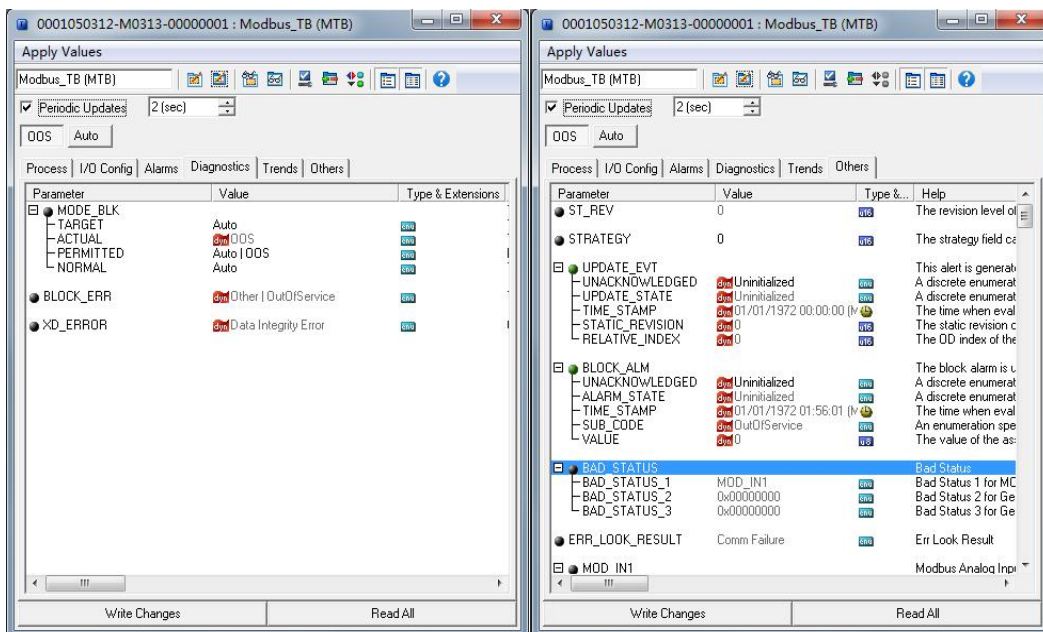

Figure 4.16 OOS situation 5 of transducer block

### Situation 6

After the device is power on, if the parameter values of XD\_ERROR function block is “Data Integrity Error”, the ERR\_LOOK\_RESULT is “Illegal Data Address”, the BAD\_STATUS is “MOD\_IN1”, it indicates

that there is read address problem in the process of normal communication. Please check the configuration of data register.

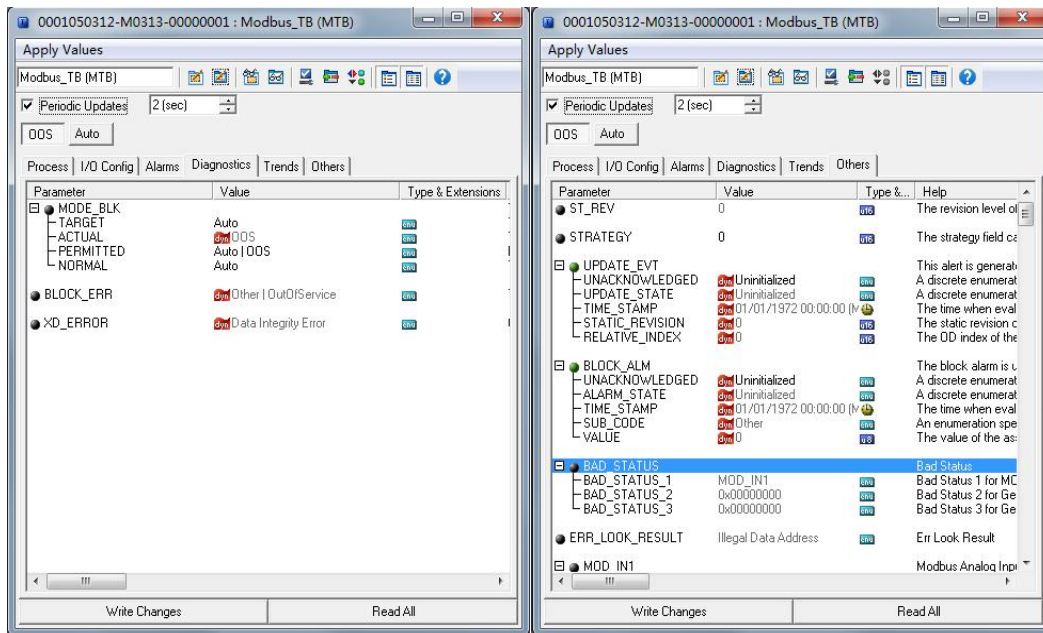

Figure 4.17 OOS situation 6 of transducer block

### Situation 7

After the device is power on, if the parameter values of XD\_ERROR function block is -Data Integrity Error, the ERR\_LOOK\_RESULT is “Illegal Function”, the BAD\_STATUS for example is “MOD\_IN1”, it indicates that there is function code matching problem in the process of normal communication. Please check the configuration of data's function code.

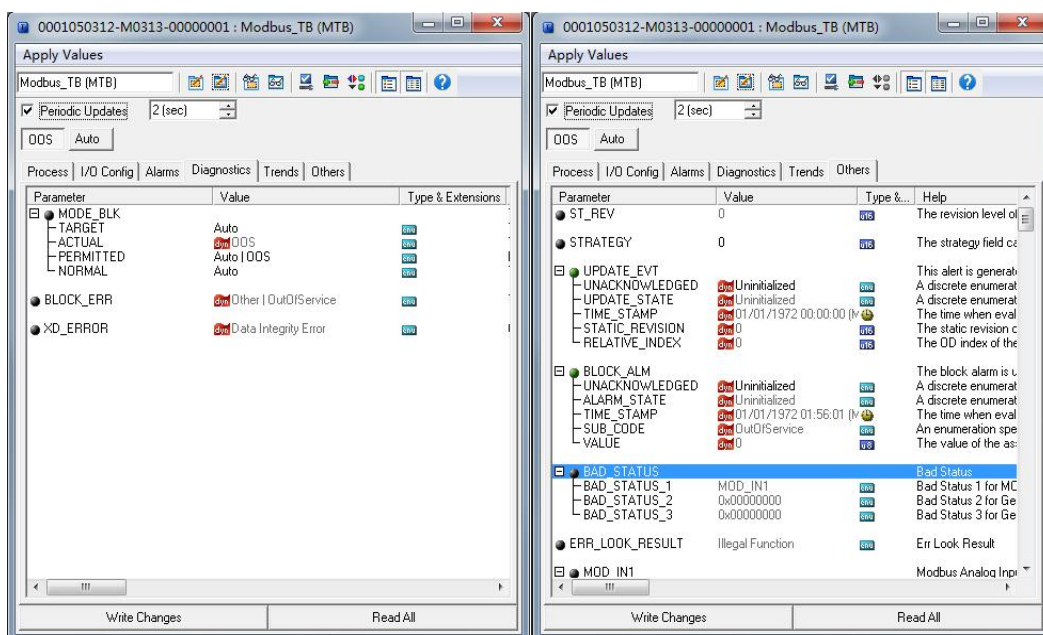

Figure 4.18 OOS situation 7 of transducer block

### Situation 8

After the device is power on, if the parameter values of XD\_ERROR function block is “Data Integrity Error”, the ERR\_LOOK\_RESULT is “Unknown Exception Code”, the BAD\_STATUS is “MOD\_IN1”, it indicates that there is problem with device in the process of normal communication, the error return code fails to be resolved. Please check the specific communication configuration of Modbus slave device.

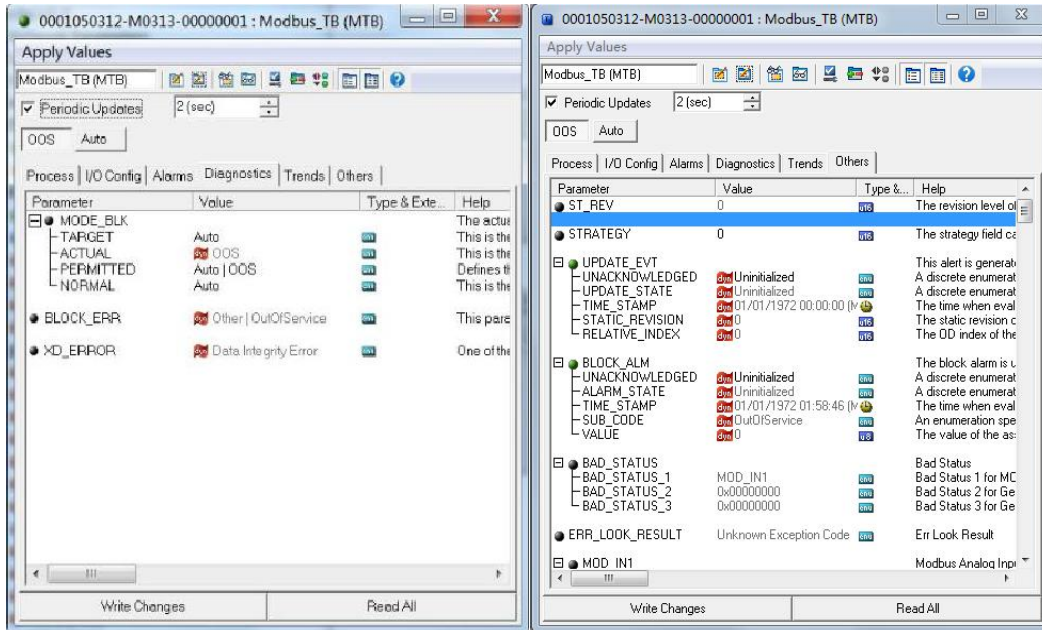

Figure 4.19 OOS situation 8 of transducer block

### Situation 8

After the device is power on, if the parameter values of XD\_ERROR function block is “Data Integrity Error”, the ERR\_LOOK\_RESULT is “Slave Device Failure”, the BAD\_STATUS is “MOD\_IN1”, it indicates that there is problem with device in the process of normal communication, the error return code is “Slave Device Failure”. Please check the status of Modbus slave device.

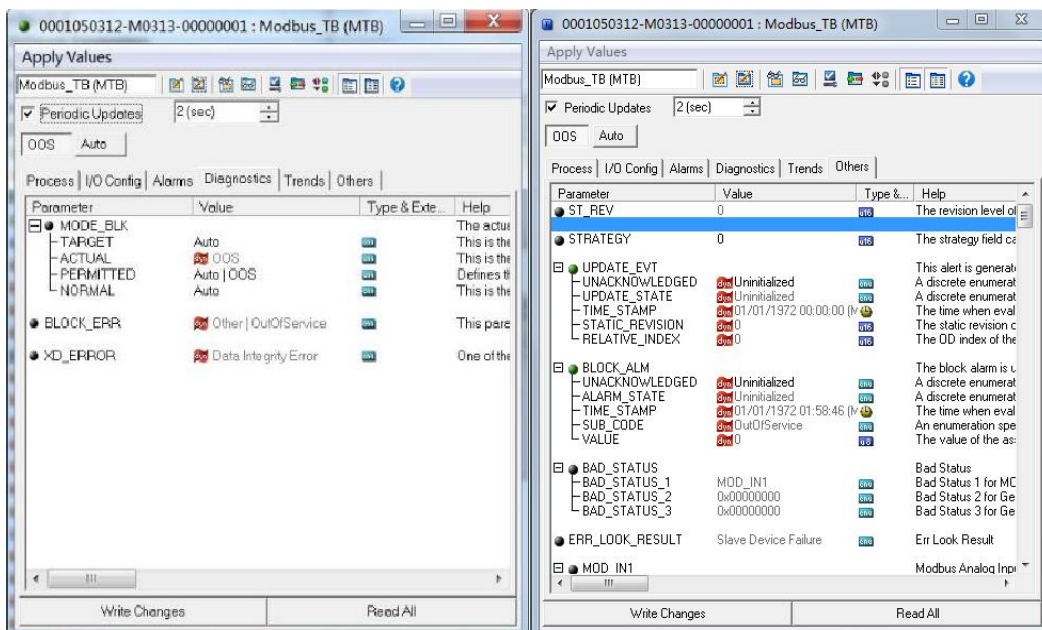

Figure 4.20 OOS situation 9 of transducer block





## 5 Maintenance

- Simple Maintenance

LED Indicator Light	Color	Normal Status	Abnormal Status	Abnormal Reason	Correction Method
FF Communication	Green	Flash	Light off	No FF communication	Check FF master and interface
				Power fault	Check power supply and connection
				Internal fault	Contact technical support
			Light on	No FF communication	Check FF master and interface
				Internal fault	Contact technical support
Modbus Communication	Green	Flash	Light off	Not connect slave device	Connect slave device
				Slave device fault	Check slave and connection
				Internal fault	Contact technical support
			Light on	In configuration mode	Check situation of eighth position M of DIP switch S2
				Not send data	Configuration fault
				Internal fault	Contact technical support

- Daily maintenance means cleaning device only.
- Fault maintenance: Please return to the factory if there's fault.



## 6 Technical Specification

### 6.1 Basic Parameters

Measure Object	Modbus RTU slave device
FF Bus Power	9~32VDC
Quiescent current	≤14mA
Bus Protocol	Two-wire, FF Protocol
Insulating Voltage	Modbus and FF bus interface, 1000VAC
Temperature Scale	-40℃~85℃
Humidity Scale	5~95%RH
Start Time	≤5s
Refresh Time	0.2s

### 6.2 Performance Index

Electromagnetic compatibility	Meet GB/T 18268.1-2010 Test method for FF port meets GB/T 18268.23-2010
-------------------------------	--

### 6.3 Physical Properties

Weight	16 g
Structural Material	Coating: Polyester epoxy resin

### 6.4 Default Communication Parameters

Slave Address	1
Baud Rate	9600
Data Bit	8
Stop Bit	1
Calibration	EVEN
CRC Calibration	Low byte ahead

### 6.5 Supportive Modbus Function Code

1	Read loop status
2	Read discrete input status
3	Read keeping register value
4	Read input register value
5	Write loop
6	Write single register values
15	Write multiple loop
16	Write multiple register values



## Appendix 1 Parameter List for Modbus Transducer Block

Index	Parameter	Data Type	Effective Range	Default Values	Storage	Functional Description
1	ST_REV	Unsigned16		0	S/RO	Static version
2	TAG_DESC	OctString(32)		Spaces	S	Bit No
3	STRATEGY	Unsigned16		0	S	Policy
4	ALERT_KEY	Unsigned8	1 to 255	0	S	Alarm
5	MODE_BLK	DS-69		O/S	S	Mode
6	BLOCK_ERR	Bitstring(2)			D/RO	Error
7	UPDATA_EVT	DS-73			D	Static data update event
8	BLOCK_ALM	DS-72			D	Function block alarm
9	TRANSDUCER_TYPE	Unsigned16		65535	N/RO	Function block type
10	XD_ERROR	Unsigned8		0	D/RO	Function block error description
11	SENSOR_TYPE	Unsigned16		65535	D/RO	Sensor type
12	BAD_STATUS	DS-258			D/RO	Consist of three 32-bit state sub-parameter, any bit is set to 1 indicates that the corresponding command gets no response, the error code of parameter could be observed by configuration.
13	ERR_LOOK_RESULT	Unsigned8	0-255		D/RO	32 I/O command negative response of exception code index address,for example 0 indicates MOD_IN1 negative response code.
14	MOD_IN1	DS-65			D/RO	Analog input 1
15	MOD_IN2	DS-65			D/RO	Analog input 2
16	MOD_IN3	DS-65			D/RO	Analog input 3
17	MOD_IN4	DS-65			D/RO	Analog input 4
18	MOD_IN5	DS-65			D/RO	Analog input 5
19	MOD_IN6	DS-65			D/RO	Analog input 6
20	MOD_IN7	DS-65			D/RO	Analog input 7
21	MOD_IN8	DS-65			D/RO	Analog input 8
22	MOD_OUT1	DS-65			D/RO	Analog output 1
23	MOD_OUT 2	DS-65			D/RO	Analog output 2
24	MOD_OUT 3	DS-65			D/RO	Analog output 3
25	MOD_OUT 4	DS-65			D/RO	Analog output 4
26	MOD_OUT 5	DS-65			D/RO	Analog output 5
27	MOD_OUT 6	DS-65			D/RO	Analog output 6
28	MOD_OUT 7	DS-65			D/RO	Analog output 7
29	MOD_OUT 8	DS-65			D/RO	Analog output 8
30	MOD_IN_D1	DS-66			D/RO	Discrete input 1
31	MOD_IN_D 2	DS-66			D/RO	Discrete input 2
32	MOD_IN_D 3	DS-66			D/RO	Discrete input 3
33	MOD_IN_D 4	DS-66			D/RO	Discrete input 4
34	MOD_IN_D 5	DS-66			D/RO	Discrete input 5
35	MOD_IN_D 6	DS-66			D/RO	Discrete input 6
36	MOD_IN_D 7	DS-66			D/RO	Discrete input 7
37	MOD_IN_D 8	DS-66			D/RO	Discrete input 8
38	MOD_OUT_D1	DS-66			D/RO	Discrete output 1
39	MOD_OUT_D 2	DS-66			D/RO	Discrete output 1
40	MOD_OUT_D 3	DS-66			D/RO	Discrete output 1
41	MOD_OUT_D 4	DS-66			D/RO	Discrete output 1
42	MOD_OUT_D 5	DS-66			D/RO	Discrete output 1
43	MOD_OUT_D 6	DS-66			D/RO	Discrete output 1
44	MOD_OUT_D 7	DS-66			D/RO	Discrete output 1
45	MOD_OUT_D 8	DS-66			D/RO	Discrete output 1
46	GENERIC_FLOAT_PARAM_1	DS-256			S	General float parameter 1
47	GENERIC_FLOAT_PARAM_2	DS-65			S	General float parameter 2
48	GENERIC_FLOAT_PARAM_3	DS-256			S	General float parameter 3
49	GENERIC_FLOAT_PARAM_4	DS-65			S	General float parameter 4
50	GENERIC_FLOAT_PARAM_5	DS-256			S	General float parameter 5
51	GENERIC_FLOAT_PARAM_6	DS-65			S	General float parameter 6
52	GENERIC_FLOAT_PARAM_7	DS-256			S	General float parameter 7
53	GENERIC_FLOAT_PARAM_8	DS-65			S	General float parameter 8
54	GENERIC_FLOAT_PARAM_9	DS-256			S	General float parameter 9
55	GENERIC_FLOAT_PARAM_10	DS-66			S	General float parameter 10
56	GENERIC_USIGN32_PARAM_1	Unsigned32			S	General 32-bit unsigned parameter 1
57	GENERIC_USIGN32_PARAM_2	Unsigned32			S	General 32-bit unsigned parameter 2
58	GENERIC_USIGN32_PARAM_3	Unsigned32			S	General 32-bit unsigned parameter 3
59	GENERIC_USIGN32_PARAM_4	Unsigned32			S	General 32-bit unsigned parameter 4
60	GENERIC_USIGN32_PARAM_5	Unsigned32			S	General 32-bit unsigned parameter 5
61	GENERIC_USIGN32_PARAM_6	Unsigned32			S	General 32-bit unsigned parameter 6
62	GENERIC_USIGN32_PARAM_7	Unsigned32			S	General 32-bit unsigned parameter 7
63	GENERIC_USIGN32_PARAM_8	Unsigned32			S	General 32-bit unsigned parameter 8
64	GENERIC_USIGN32_PARAM_9	Unsigned32			S	General 32-bit unsigned parameter 9
65	GENERIC_USIGN32_PARAM_10	Unsigned32			S	General 32-bit unsigned parameter 10
66	GENERIC_USIGN16_PARAM_1	Unsigned16			S	General 16-bit unsigned parameter 1



67	GENERIC_USIGN16_PARAM_2	Unsigned16			S	General 16-bit unsigned parameter 2
68	GENERIC_USIGN16_PARAM_3	Unsigned16			S	General 16-bit unsigned parameter 3
69	GENERIC_USIGN16_PARAM_4	Unsigned16			S	General 16-bit unsigned parameter 4
70	GENERIC_USIGN16_PARAM_5	Unsigned16			S	General 16-bit unsigned parameter 5
71	GENERIC_USIGN16_PARAM_6	Unsigned16			S	General 16-bit unsigned parameter 6
72	GENERIC_USIGN16_PARAM_7	Unsigned16			S	General 16-bit unsigned parameter 7
73	GENERIC_USIGN16_PARAM_8	Unsigned16			S	General 16-bit unsigned parameter 8
74	GENERIC_USIGN16_PARAM_9	Unsigned16			S	General 16-bit unsigned parameter 9
75	GENERIC_USIGN16_PARAM_10	Unsigned16			S	General 16-bit unsigned parameter 10
76	GENERIC_USIGN8_PARAM_1	Unsigned8			S	General 8-bit unsigned parameter 1
77	GENERIC_USIGN8_PARAM_2	Unsigned8			S	General 8-bit unsigned parameter 2
78	GENERIC_USIGN8_PARAM_3	Unsigned8			S	General 8-bit unsigned parameter 3
79	GENERIC_USIGN8_PARAM_4	Unsigned8			S	General 8-bit unsigned parameter 4
80	GENERIC_USIGN8_PARAM_5	Unsigned8			S	General 8-bit unsigned parameter 5
81	GENERIC_USIGN8_PARAM_6	Unsigned8			S	General 8-bit unsigned parameter 6
82	GENERIC_USIGN8_PARAM_7	Unsigned8			S	General 8-bit unsigned parameter 7
83	GENERIC_USIGN8_PARAM_8	Unsigned8			S	General 8-bit unsigned parameter 8
84	GENERIC_USIGN8_PARAM_9	Unsigned8			S	General 8-bit unsigned parameter 9
85	GENERIC_USIGN8_PARAM_10	Unsigned8			S	General 8-bit unsigned parameter 10
86	GENERIC_STRINGV_PARAM_1	Octet String(32)			S	General 32-bit strings parameter 1
87	GENERIC_STRINGV_PARAM_2	Octet String(32)			S	General 32-bit strings parameter 2



## Appendix 2 Common parameter list

No	Parameter	Description
1	Data configure flags	Data configure flags 0xFEDCCDEF: Data Valid 0x00000000: Data Invalid
2	Device's serial number	Device's serial number SN ( 6 bytes )
3	Number of analog input data	Number of analog input data (0~8)
4	Number of analog output data	Number of analog output data (0~8)
5	Number of input digital data	Number of input digital data (0~8)
6	Number of output digital data	Number of output digital data (0~8)
7	Number of float data	Number of float data (0~10)
8	Number of USIGN32 data	Number of USIGN32 data (0~10)
9	Number of USIGN16 data	Number of USIGN16 (0~10)
10	Number of USIGN8 data	Number of USIGN8 data (0~10)
11	Number of data Octet String	Number of data Octet String (0~2)
12	Baud rate	Baud Rate 0: 2400 1: 4800 2: 9600 3: 14400 4: 19200
13	Data bit	Data bit 0: 8 1: 7
14	Check bit	Check bit 0: None 1: Even 2: Odd
15	Physical standard	Interface type 0: TTL 1: RS232 2: RS485
16	Stop bit	Stop bit 0: One Stop Bit 1: Two Stop Bits
17	Address	Slave station address(1~255), this address is the slave station address under normal working mode
18	CRC	CRC Sequence-checking 0: Normal 1: Swapped
19	Timeout	Timeout value (300~1000, unit ms)
20	Resend times	Resend times (1~10)
21	View error parameter	View error parameter (0~73, all the 74 channel datas, which respectively indicate analog input,analog output, digital input, digital output, float data, USIGN32 data 、 USIGN16 data 、 USIGN8 data and Octet String data)



## Appendix 3 Model Selection Table for M0313 Module

<b>MOD-FFH1</b>	<b>M0313 Modbus to FF built-in module</b>					
	Code	Master/Slave				
	M	Master Station				
		Code	Module Form			
		N	General			
			Code	Hardware Interface		
			T	TTL level		
				Code	Software Interface	
				M	Modbus RTU	
					Code	Bus interface on module
					N	No Bus interface
MOD-FFH1-	M	N	T	M	N	— Selection Example



# MICROCYBER

## YOUR FIELDBUS EXPERT

### CONTACT INFORMATION

**Address:** 17-8 Wensu Street, Hunnan New District, Shenyang, China

**Website:** [www.microcyber-fieldbus.com](http://www.microcyber-fieldbus.com)

**Phone:** +86-15840504862

**Fax:** +86-24-31217338

**Email:** [guo.ruibing@microcyber.cn](mailto:guo.ruibing@microcyber.cn)