



NCS-PT105 II Series Smart Pressure Transmitter





FIELDCOMM GROUP™
Connecting the World of
Process Automation



HART
COMMUNICATION PROTOCOL



CERTIFICATE OF MEMBERSHIP

The Board of Directors hereby acknowledges that

Microcyber Corporation

has accepted and fulfilled the requirements of the Bylaws
and all rights and privileges of membership are hereby granted

Membership Term: November 2019 – October 2020



President and CEO



Certificate of Registration
FieldComm Group Verified

| | |
|---|---|
| <u>Microcyber Corporation</u> Manufacturer | <u>NCS-PT105 II</u> Product Name |
| <u>601E</u> Manufacturer ID (Hex) | <u>E0B3</u> Expanded Device Type (Hex) |
| <u>7</u> HART Protocol Revision | <u>02</u> Device Revision (Hex) |
| <u>02</u> Hardware Revision (Hex) | <u>39</u> Software Revision (Hex) |
| <u>5/12/2016</u> Test Date | <u>FieldComm Group</u> Verification Method |

The above product has successfully completed the validation process and meets the requirements to be "HART REGISTERED".

"HART REGISTERED" products conform to GB/T 29910.1-6-2013 and IEC 61158 standards.

Registration Number: L2-06-1000-549 Registration Issue Date: June 16, 2016 Approval: T. Y. Mastus



FIELD COMM GROUP™
*Connecting the World of
Process Automation*

HART® is a registered trademark of FieldComm Group.

Certificate

PROFIBUS Nutzerorganisation e.V. grants to

Microcyber Corporation

17-8 Wensu Street, Hunnan New District, 110179 Shenyang, China

the Certificate No: **Z01316** for the PROFIBUS Device:

Model Name: NCS-PT105II
Revision: 03.00; SW/FW: 03.00; HW: 1.3
GSD: MCYB0B25.gsd; File Version: 5.0
PA139700.gsd

This certificate confirms that the product has successfully passed the certification tests with the following scope:

| | |
|--|------------------------------------|
| <input checked="" type="checkbox"/> DP-V0 | MS0, Freeze, Set_Slave_Add |
| <input checked="" type="checkbox"/> DP-V1 | Prm_Block_Structure, MS1, MS2, I&M |
| <input checked="" type="checkbox"/> Profile | PROFIBUS PA 3.02 |
| <input checked="" type="checkbox"/> Physical Layer | MBP |

Test Report Number: MCDL-2013-817-D
Authorized Test Laboratory: ITEI, Beijing, China

The tests were executed in accordance with the following documents:
"Test Specifications for PROFIBUS DP Slaves, Version 3.0.9, September 2008" and
"Test Specifications for PROFIBUS PA Profile 3.0.2, Version 5.0.4, February 2010".

This certificate is granted according to the document:
"Framework for testing and certification of PROFIBUS and PROFINET products".

For all products that are placed in circulation by **January 26, 2020** the certificate is valid for life.

Karlsruhe, January 16, 2017

Board of PROFIBUS Nutzerorganisation e. V.



(Official in Charge)



(Karsten Schneider)

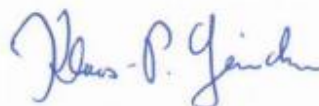

(K.-P. Lindner)

检测报告

Test Report

| | | | |
|-----------------------|--|---------------------|------------------------------------|
| 样品名称 Name of EUT | 智能压力变送器 | 型号/规格 Model/Type | NCS-PT105 II SG7F-22M ₅ |
| 委托单位 Customer | 沈阳中科博微自动化技术有限公司 | 地址 Address | 辽宁省沈阳市东陵区南塔街 114 号 |
| 制造单位 Manufacturer | 沈阳中科博微自动化技术有限公司 | 地址 Address | 辽宁省沈阳市东陵区南塔街 114 号 |
| 检测项目 Test Item (s) | 1) 辐射骚扰 2) 工频磁场抗扰度 3) 射频电磁场辐射抗扰度 4) 射频场感应的传导骚扰抗扰度 5) 静电放电抗扰度 6) 浪涌 (冲击) 抗扰度 7) 电快速瞬变脉冲群抗扰度 | | |

分包无 有 / 分包项目 / 分包单位
 Subcontract No Yes Item(s) Subcontracted Subcontractor

检测依据 Q/BW04-2007 《智能压力变送器》
 Test Standard/ Specification GB/T 18268-2000 《测量、控制和实验室用的电设备电磁兼容性要求》

受样方式 送样 抽样 / 抽样程序
 Method of Getting EUT Delivered by Client Sampled Sampling Procedure

样品接收日期 2008 年 4 月 15 日 样品数量 壹台
 Date of Getting EUT 2008 Year 4 Month 15 Day Number of EUT 壹台
 样品编号 No.1
 Serial No. of EUT No.1

检测日期 2008 年 4 月 15 日 至 2008 年 4 月 18 日
 Date of Testin 2008 Year 4 Month 15 Day to 2008 Year 4 Month 18 Day

检测结论 合格
 Conclusion 合格

| | | | |
|---------------------------|------------|-----------------|--------------|
| 报告撰写人: Prepared by | <u>张杰</u> | 职务/职称: Title | <u>助理工程师</u> |
| 项目负责人: Project Manager | <u>翁沙丰</u> | 职务/职称: Title | <u>助理工程师</u> |
| 审 定: Approved by | <u>陆济峰</u> | 职务/职称: Title | <u>高级工程师</u> |
| 批 准: Authorized by | <u>姚克亮</u> | 职务/职称: Title | <u>高级工程师</u> |

检测单位 上海仪器仪表自控系统检验测试所 被认可/授权机构名称
 Testing Organization Shanghai Inspection and Testing Institute of Instruments and Automatic Systems (SITIIS) Accredited/Authorized Organization

上海仪器仪表自控系统检验测试所
 Shanghai Inspection and Testing Institute of
 Instruments and Automatic Systems (SITIIS)

报告编号: C08-092-WT

第 1 页 共 11 页
 Page of

Report No.

声明: 1. 本检测报告仅对受试样品有效。

Statement This test report refers only to the sample(s) tested.

2. 未经本实验室书面认可不得复制 (完整复制除外) 本报告。

This test report shall not be reproduced except in full, without the written approval of the laboratory.

检测报告

Test Report

| | | | |
|-----------------------|-----------------|---------------------|-----------------|
| 样品名称 Name of EUT | 智能压力变送器外壳 | 型号/规格 Model/Type | NCS-PT105 II |
| 委托单位 Customer | 沈阳中科博微自动化技术有限公司 | 地址 Address | 沈阳市浑南新区飞云路 18 号 |
| 制造单位 Manufacturer | 沈阳中科博微自动化技术有限公司 | 地址 Address | 沈阳市浑南新区飞云路 18 号 |
| 检测项目 Test Item (s) | 防尘防水 (IP67) | | |

分包无 有 / 分包项目 / 分包单位 /
 Subcontract No Yes Item(s) Subcontracted Subcontractor



检测依据 GB 4208-1993 《外壳防护等级 (IP 代码)》
 Test Standard/ Specification

取样方式 送样 抽样 / 抽样程序 /
 Method of Getting EUT Delivered by Client Sampled Sampling Procedure

样品接收日期 2008. 6. 30 样品数量 壹只
 Date of Getting EUT Number of EUT
 样品编号 PH070046
 Serial No. of EUT

检测日期 2008 年 6 月 30 日至 2008 年 6 月 30 日
 Date of Testing Year Month Day to Year Month Day

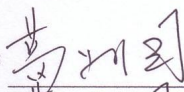
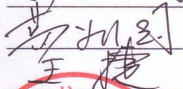
检测结论 合格
 Conclusion

| | | |
|---------------------------|---|-----------------------|
| 报告撰写人: Prepared by |  | 职务/职称: 助理工程师 Title |
| 项目负责人: Project Manager |  | 职务/职称: 助理工程师 Title |
| 审 定: Approved by |  | 职务/职称: 高级工程师 Title |
| 批 准: Authorized by |  | 职务/职称: Title |

检测单位
 Testing Organization
 上海仪器仪表自控系统检验测试所
 Shanghai Inspection and Testing Institute of
 Instruments and Automatic Systems (SITIIS)

被认可/授权机构名称
 Accredited/Authorized Organization

报告编号: C08-152-WT

Report No.

声明: 1. 本检测报告仅对受试样品有效。

Statement This test report refers only to the sample(s) tested.

2. 未经本实验室书面认可不得复制 (完整复制除外) 本报告。

This test report shall not be reproduced except in full, without the written approval of the laboratory.

第 1 页 共 3 页
 Page of

Company Introduction

Microcyber Inc. established as a high-tech enterprise by the Shenyang Institute of Automation Chinese Academy of Sciences, mainly engages in advanced industrial control systems, equipments, instruments and chips for industrial process automation control solutions in the research, development, production and application. Microcyber undertakes a number of national scientific and technical key task and “863” project, and has Liaoning Province networked control systems engineering research center. The company successfully developed the FF H1 fieldbus protocol stack which is number one to be approved internationally in China, and the Industrial Ethernet Protocol(HSE) which is number one to be approved in China, and the domestic first fieldbus instrument which has a function of national-level intrinsically safe explosion--proof and safety barrier. Also Microcyber participated in the drafting of the domestic first Ethernet-based industrial automation protocol standards (Ethernet for Plant Automation, EPA). As a result, serial products are composed of configuration, control software, embedded software, control system, instrument chip to the OEM board, and make Microcyber be an industrial automation products provider in full range, and also further Microcyber’s leading position in the field of fieldbus technology.

Microcyber is the FF member, the HART member and the Profibus National Organization (PNO) member.

Microcyber passes the Authentication of ISO 9001 Quality System, and has an outstanding innovative R&D team, plentiful practical experiences of design of the Automatic engineering, a leading product series, a huge market network, a strict quality management system and an excellent enterprise culture. All these further a solid foundation of entrepreneurship and sustainable development for Microcyber.

Microcyber Inc. is looking forward to the long-term smooth and close cooperation with you.

Content

| | |
|--|----|
| Chapter 1 Introduction..... | 1 |
| Chapter 2 Installation..... | 4 |
| 2.1 Transmitter Installation..... | 4 |
| 2.2 Inlet Pressure Pipe Installation..... | 4 |
| 2.3 Wiring..... | 6 |
| 2.4 Re-Calibration Tesing..... | 7 |
| 2.5 Installation of Explosion-proof Type Transmitters..... | 7 |
| Chapter 3 Working Principle and Structure..... | 9 |
| 3.1 Introduction for Working Principle..... | 9 |
| 3.2 Construction Introduction..... | 11 |
| Chapter 4 Adjusting in Workplace..... | 13 |
| 4.1 Operation Instruction for Magnetic Sticks..... | 13 |
| 4.2 Adjusting for HART Smart Transmitter..... | 14 |
| 4.3 Adjusting for FF Smart Transmitter..... | 19 |
| 4.4 Adjusting for PA Smart Transmitter..... | 22 |
| 4.5 Return instrument data to factory data..... | 28 |
| Chapter 5 Configuration of HART Smart Transmitter..... | 29 |
| 5.1 Topologic Connection..... | 29 |
| 5.2 Function Configuration..... | 30 |
| 5.3 Jump-pin Configuration..... | 33 |
| Chapter 6 Configuration of FF Smart Transmitter..... | 34 |
| 6.1 Topologic Connection..... | 34 |
| 6.2 Function Block..... | 35 |
| 6.3 Function Configuration..... | 35 |
| 6.4 Jumper-pin Configuration..... | 40 |
| Chapter 7 Configuration of PA Smart Transmitter..... | 41 |
| 7.1 Topology Connection..... | 41 |
| 7.2 Function Block..... | 41 |
| 7.3 Function Configuration..... | 42 |
| 7.4 Jump-pin Configuration..... | 50 |
| Chapter 8 Maintain..... | 51 |
| Chapter 9 Technical Specifications..... | 52 |
| 9.1 Basic Parameter..... | 52 |
| 9.2 Performance Index..... | 53 |
| 9.3 Physical Properties..... | 53 |
| Appendix Smart Transmitter Selection..... | 55 |



Chapter 1 Introduction

NCS-PT105 II series Smart Pressure Transmitter with advanced, mature, reliable 3151 capacitance sensors has been designed meticulously by combining advanced microprocessor technology and digital capacitance measurement technology. The powerful functions and high-speed computing capability of the microprocessor make it have excellent qualifications such as smart, high precision, high reliability, stable zero and so on. Its LCD can display many physical parameters (e.g. pressure, temperature, current and so on). It can realize the functions such as zero adjustment, range settings by key-press operation, and it is easy for field testing.

NCS-PT105 II series Smart Pressure Transmitter supports HART, FF, and PA protocol and can measure pressure, differential pressure, liquid level, flow, and other industrial parameters. It can be widely used in the petroleum, chemicals, electricity, and metallurgical industries, etc..

According to the type of measurable pressure:

| Model | Pressure type |
|-----------------|--|
| NCS-PT105 II SG | Gauge pressure transmitter |
| NCS-PT105 II SA | Absolute pressure transmitter |
| NCS-PT105 II SD | Differential pressure transmitter |
| NCS-PT105 II SH | Differential pressure transmitter for high static pressure |

According to the protocol:

| Model | Communication Protocol type |
|----------------|-----------------------------|
| NCS-PT105 II H | HART |
| NCS-PT105 II F | FF H1 |
| NCS-PT105 II P | PROFIBUS PA |

As a transitional communication protocol in fieldbus, HART protocol achieves digital transmission on the existing analog transmission lines, and is compatible with existing analog signal control system. Either FF H1 or PROFIBUS PA is a new generation of digital communication protocol, used in field connection, and linking field devices. International Standard IEC61158-2 is used in physical layer. Therefore, either FF H1 or PROFIBUS PA is fieldbus actually.

As following, Smart Transmitter with HART protocol is named as **HART Smart Transmitter**; Smart Transmitter with FF H1 protocol is named as **FF Smart Transmitter**; Smart Transmitter with PROFIBUS PA protocol is named as **PA Smart Transmitter**, All of these (Transmitters with the three types of fieldbus protocol) are named as **Smart Pressure Transmitters** or **Smart Transmitters**. In addition, HART Smart Transmitter has passed explosion-proof certification from National Supervision and Inspection Center for Explosion Protection and Safety of Instrumentation (NEPSI).

- Smart Transmitters Size shown as Figure 1-1:

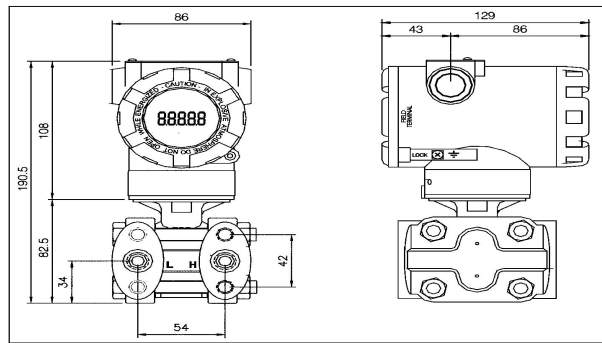

Figure 1-1 Smart Transmitter Size (Unit: mm)

- Smart Transmitter Structure shown as Figure 1-2:

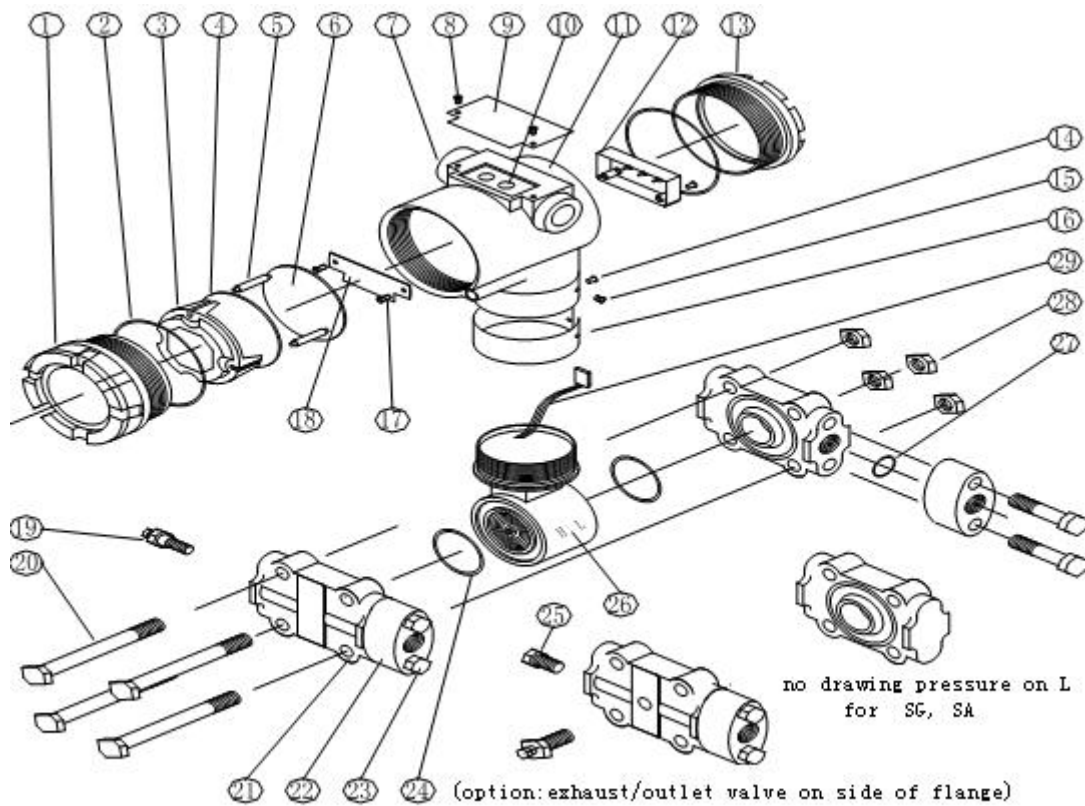

Figure 1-2 Smart Transmitter Structure



| | | | | | | | |
|----|----------------------|----|---------------------|----|----------------------|----|------------------|
| 1 | Front cover | 2 | O-ring | 3 | Display card hosing | 4 | LCD card |
| 5 | Location Column | 6 | Communication board | 7 | Wiring hole | 8 | Name plate screw |
| 9 | Name plate | 10 | Z/S hole | 11 | Electric housing | 12 | Pin board |
| 13 | Rear cover | 14 | Lock screw | 15 | Brand plate screw | 16 | Brand plate |
| 17 | Screw | 18 | Terminal board | 19 | Exhaust/outlet valve | 20 | Bolt |
| 21 | Flange | 22 | Transition joint | 23 | Bolt | 24 | O-ring |
| 25 | Vent/flange adapter | 26 | Sensor | 27 | O-ring | 28 | Screw |
| 29 | Instrument card wire | | | | | | |

Note: The terminal board and communication board for FF Smart Transmitter are identical to those of PA Smart Transmitter, but the components are different from the components of HART Smart Transmitters. The size is the same as that of HART, as well as the installation except for the fixed screw position of terminal cards. Therefore, there is no structure shown for FF Smart Transmitter and PA Smart Transmitter.

Chapter 2 Installation

The measurement accuracy of the smart transmitter depends largely on the correct installation of the smart pressure transmitter and the pressure inlet tube. In particular, the measurement of the flow mainly relates to the correct installation of a measurement device.

2.1 Transmitter Installation

For transmitter installation, three types of bracket are provided (pipe mounting flat bracket, pipe mounting angle bracket, and plate mounting angle bracket). Accordingly there are three installation methods as the following.

The installation of pipe mounting flat bracket: the typical installation as Figure 2-1 shows. Fix transmitter in flat bracket using four bolts provided, and then fix the flat bracket on the vertical pipe of $\Phi 50\text{mm}$ around with the U-shape bolt provided.

The installation of pipe mounting angle bracket: the typical installation as Figure 2-2 shows. Fix transmitter in angle bracket using four bolts provided, and then fix the angle bracket on the horizontal pipe of $\Phi 50\text{mm}$ around with the U-shape bolt provided.

The installation of plat mounting angle bracket: the typical installation as Figure 2-3 shows. Fix transmitter in angle bracket using four bolts provided, and then fix the angle bracket on the plate with the M10 bolt.

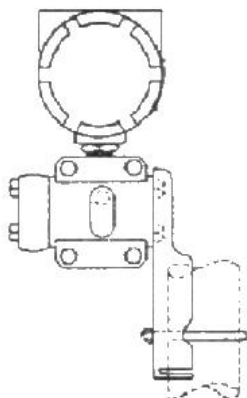

Figure 2-1 The installation of pipe mounting of flat bracket

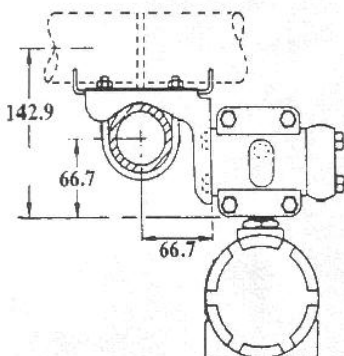

Figure 2-2 The installation of pipe mounting angle bracket

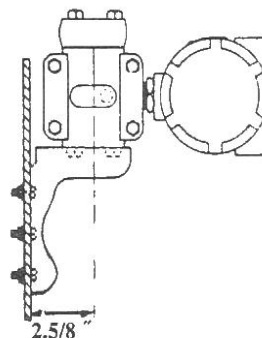

Figure 2-3 The installation of plate mounting angle bracket

2.2 Inlet Pressure Pipe Installation

The correct installation of pipeline depends on the measurement medium. Smart transmitter can measure liquid, steam or other gases. The pressure port, smart transmitter and related position of flow pipe are different according to different measurement medium.

Liquid: The pressure port must be selected on side of the flow pipe to avoid slag deposition. Smart transmitter should be installed under the pressure port, so that the gas

can be drained into flow pipe. As shown in Figure 2-4.

Stream: The Inlet pressure pipe must be installed on the side of the flow pipe, and smart transmitter must be installed under the pressure port. The inlet pressure pipe should be filled with water to prevent the direct contact between smart transmitter and stream. Smart transmitter should not exceed the working temperature limit when stream or other high temperature medium is measured. As shown in Figure 2-5.

Gas: The pressure port should be installed on the top or on the side of the flow pipe. Smart transmitter should be installed on the top of the pressure port, so that the liquid can be drained into flow pipe. As shown in Figure 2-6.

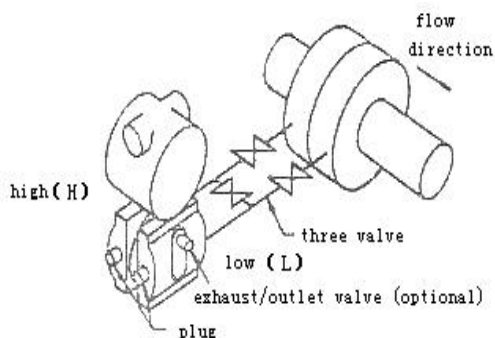

Figure 2-4 Installation for liquid medium connection

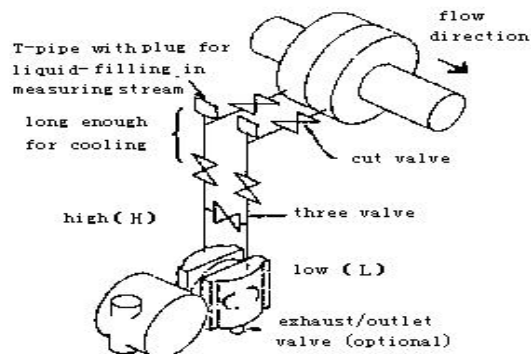

Figure 2-5 Installation for stream medium connection

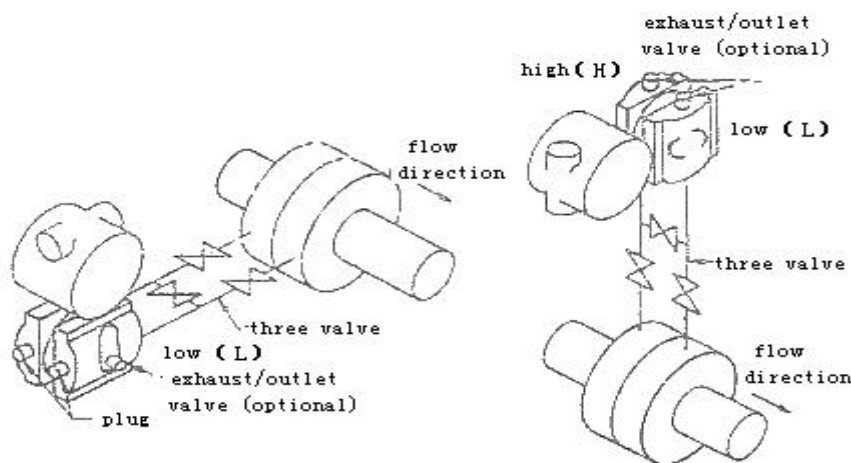

Figure 2-6 Installation for gas medium connection

Notes:

- 1) The inlet pressure pipe should be as short as possible in the case of meeting the needs.
- 2) Corrosive or overheated medium should not be contacted with the transmitter directly.
- 3) The inlet pressure pipe should be installed in the place where the temperature gradient is low and fluctuation is small.
- 4) Working temperature limit must be paid attention to when high temperature medium is to measure.
- 5) For differential pressure transmitter, the two inlet pressure pipes should be

kept at the same temperature, and the hydraulic height should be kept balance (For differential type).

- 6) The inlet pressure pipe should use large-diameter pipe as far as possible in case of the friction effect.
- 7) For differential pressure transmitter, the liquid-level of the two inlet pressure pipes should be kept at the same height when isolating gas is used.
- 8) When injection system is used, the system should be as close as possible to the pressure port of flow pipe. And the purifying liquid should get through from the pipes of the same size, length of pipes to the transmitter. Also the injection liquid through transmitter should be avoided (For differential type).

2.3 Wiring

The power and signal of Smart Transmitter are sharing one pair of cables (Bus Cable). The ordinary cables can be selected by HART smart transmitter, but FF, PA Smart Transmitter is suggested to use specific Fieldbus cable the IEC61158-2 recommended. The terminal is at the rear cover, the terminal wiring board could be seen after screwing the rear cover (indicated "FIELD TERMINAL").

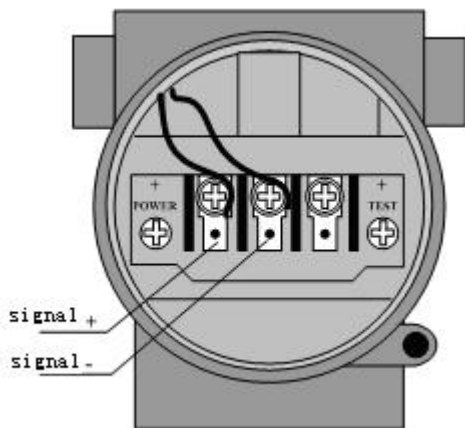

Figure 2-7 FF, PA Smart Transmitter wiring

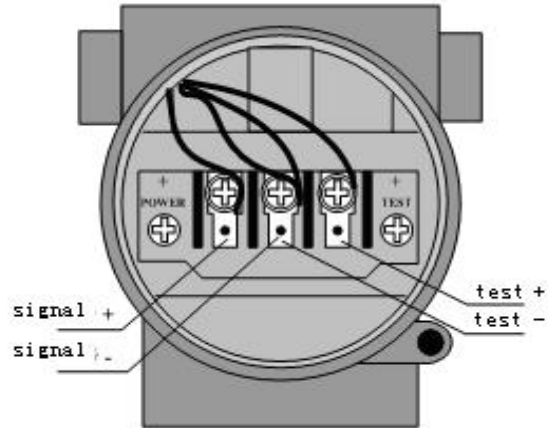

Figure 2-8 HART Smart Transmitter wiring

The left terminal of the terminal wiring board is "+" signal terminal, the right terminal is testing "+" terminal, and the middle terminal is "-" signal and testing "-" terminal (sharing). Power supply is provided to smart transmitter with signal wire. The testing terminal is only used in HART smart transmitter to connect the testing instrument.

Signal wires should be holed to wire terminal through the wiring hole. And "+" signal wire should be connected to the "+" signal terminal (left), the "-" signal wire should be connected to the "-" signal terminal (middle) (Figure 2-7). Signal wires shielded layer can be floating ground, is also available for single-point grounding at any point in the signal circuit. When the testing instrument is connected to test the analog signal of the HART smart transmitter, thread method is also in the same way of the signal wire, but the "+" test

wire should be connected to the right terminal of the terminal wiring board in HART smart transmitter, and the “-” test wire should be connected to the middle terminal (Figure 2-8).

Caution: When connecting the HART smart transmitter, do not connect the signal wire to the testing terminal. It will damage the diodes. But when the diodes are burnt, the emergency response is to short the circuit of the two testing terminal.

The Bus Cable of smart transmitter should not share the line pipe or trunkings with other device, and should be away from high-power device.

2.4 Re-Calibration Tesing

Before smart transmitter is used, re-calibration testing should be done in lab or in the field. Figure 2-9 shows the operation procedure:

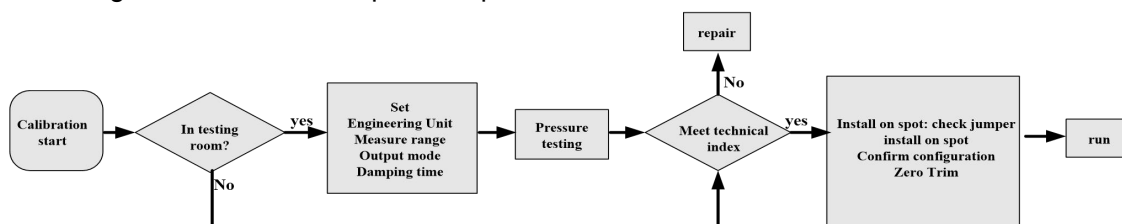

Figure 2-9 Calibration Procedure

The content of smart transmitters re-calibration includes function testing and pressure testing. Please refer to the following chapter about the methods in detail.

2.5 Installation of Explosion-proof Type Transmitters

HART Smart Transmitter has passed the national-level intrinsically safe explosion-proof certification, and this type includes “IC” in its product type name. The description of this section is just about this type.

Smart transmitter must be connected to safety barrier when used in dangerous places, where the explosive mixtures could be in it. The selection about the type and parameter of safety barrier must be referred to the table below. Suffixes X of Explosion-proof certification number indicates that this product must be composed of the intrinsically safe explosion-proof system with isolated safety barrier, or every ground point of the intrinsically safe explosion-proof system, where this product is exactly in, must kept in equal-potential balance.

National Supervision and Inspection Center for Explosion Protection and Safety of Instrumentation (NEPSI) certified parameter of smart transmitter as following:

| | | | |
|-------------------------------|--------------|---------------------------|---------|
| Certification number | GYB071520X | Maximum input-voltage | 30V DC |
| Explosion-Proof Mark | Ex ia IIC T4 | Maximum input-current | 100 mA |
| Environment temperature | -30 ~ +60 °C | Maximum input-power | 0.8 W |
| Measurable medium temperature | -40~ +110 °C | Maximum internal capacity | About 0 |
| | | Maximum internal inductor | 0.11 mH |



| | | | |
|------------------------------|--------------|---------------------------|---------|
| Certification number | GYB071520X | Maximum input-voltage | 28V DC |
| Explosion-Proof Mark | Ex ia IIC T4 | Maximum input-current | 93mA |
| Environment temperature | -30 ~ +50 °C | Maximum input-power | 0.66 W |
| Measurable media temperature | -40~ +70 °C | Maximum internal capacity | About 0 |
| | | Maximum internal inductor | 0.11 mH |

Notes:

- 1) **The housing of smart transmitter must be grounded well.**
- 2) **As for the circuit of the smart transmitter, user could not disassemble or replace components.**
- 3) **The calculation of maximum distributed parameter of signal wire must be referred to the parameter of safety barrier and parameter of explosion-proof selected.**
- 4) **The cable of smart transmitters signal must be isolated from other cable, and shielded by steel pipe or trunkings.**
- 5) **The shielded layer of smart transmitters signal wire must be single-point grounded or float grounded.**
- 6) **The safety barrier must be installed on the frame at the outlet of safety area.**

Chapter 3 Working Principle and Structure

The measurement principle of smart transmitter based on the 3151 capacitive pressure sensor, using advanced micro-controller technology, sensor digital measurement technology and high accuracy algorithm to ensure the high-precision pressure measurement. The advanced HART, FF H1 and PROFIBUS PA Fieldbus technologies are used respectively by the communication interface of smart transmitter.

The logical structure of smart transmitter, which is the same, can be divided into five parts: sensor, instrument card, communication card, LCD card and port card, as Figure 1-2 and Figure 3-1 shows. The FF, PA Smart Transmitters are identical in terms of hardware due to the same physical layer specification, the communication card and port card of the FF, PA Smart Transmitters are different from those of Hart, but other parts are the same.

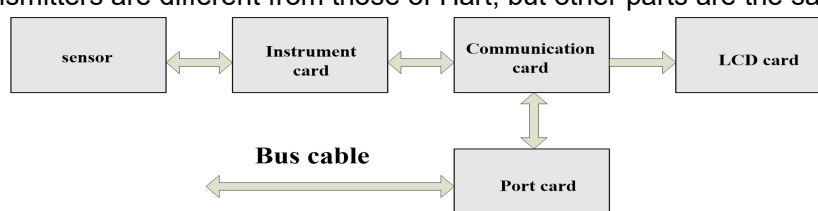

Figure 3-1 Structure

3.1 Introduction for Working Principle

The widely used 3151 capacitive pressure sensors, which were developed by Rosemount initially in USA, have been produced on a large scale in China. The core of its sensor is differential capacitive membrane, as Figure 3-2 shows. There are two measurement capacitances CH and CL distributed in differential capacitive membrane. The two measurement capacitances are almost equal to two plate capacitances because of their mechanical structure. The two measurement capacitances share one polar plate, which is a measure membrane in the center. And the other polar plate is fixed on the two sides. When the pressures of two sides are equal, the measure membrane is in the center, the capacitances of two sides are equal too. But when the pressure of high pressure side is higher than that of low pressure side, the guide pressure liquid filled in the membrane guides the differential pressure, so that the measure membrane moves to low pressure side. As a result, the capacitance of high pressure side is lower than that of the low pressure side.

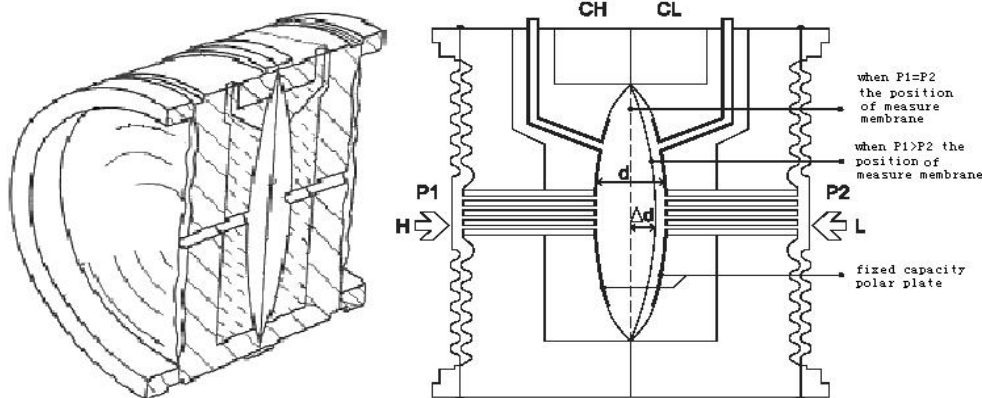

Figure 3-2 Sensor Capacitance Membrane

When the displacement of the Measure Membrane is shorter than the thickness of its own, there will be a linear relationship between the displacement and the differential pressure.

$$\Delta d = K1\Delta P \quad (3-1)$$

The capacitance of the plate capacitor has a reciprocal relationship with the distance of the polar, that is, a nonlinear relationship. However, when the differential capacitance structure is used, the distance has a linear relationship with the ratio of the difference between the measure capacitance and the sum of the measure capacitance.

$$(CL - CH)/(CL + CH) = \Delta d K2 \quad (3-2)$$

Take the (3-1) into (3-2) :

$$(CL - CH)/(CL + CH) = K1K2\Delta p$$

$K1K2$ is the constant determined by the membrane structure. Therefore, the result is that there is a linear relationship between the differential pressure Δp and the ratio of the difference between the measure capacitance and the sum of the measure capacitors. $(CL - CH)/(CL + CH)$ is obtained. If the ratio is got, the differential pressure can be got. The instrument board of smart transmitter is responsible for measuring the ratio referred above. The instrument board, using digital technology, translates the change of the capacitance of the two measure capacitors into the change of the counting value firstly, and then calculates the ratio $(NL - NH)/(NL + NH)$. The instrument board is also responsible for real-time temperature acquisition, and uploads it with radio to the communication board.

The communication board are not only responsible for the communication between the smart transmitter and the Protocol Fieldbus, but also upload the differential pressure which is calculated using the data supplied by the instrument and the calibration parameter, to the device in the upper layer via separate protocol. The communication board of HART smart transmitter can control the output of D/A according to the differential pressure calculated, to carry out the control of analog current signals. The communication board can control LCD board to carry out present condition and measurement pressure value of the smart transmitter.

Terminal board supplies a simple signal interface for the communication board.

3.2 Construction Introduction

The differential capacitance membrane is encapsulated in the sensor, and through three capacitance polar cables which are extracted. The capacitance polar are welded on the measurement membrane and fixed polar separately. And the Flange is tightly-ferruled on the both sides of the sensitive device by four bolts. As a result, the sensor is formed, as Figure 3-3 shows.

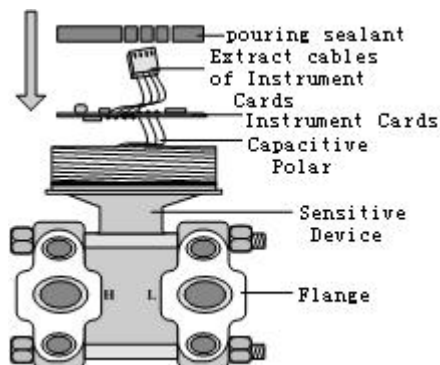

Figure 3-3 Sensor and Instrument Board

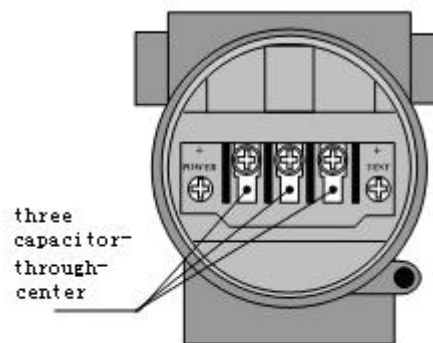

Figure 3-4 Sensor and Instrument Board

The instrument board is installed in the sensitive device of the smart transmitter. The capacitance polar of the sensitive device is welded on the interface of the measurement capacitance in the instrument board. The pouring sealant, which has effects of insulation and conduction, fixes the instrument board in the cavity reserved by the sensitive device. And the four-core cable of instrument board is reserved outside, which can be used to connect the communication board.

Three capacitance-through-center with thread are wringed in the hole of the housing, one polar is extended to the cavity of instrument and connected to the terminal board, and the other one is weld on the three terminals on the terminal block separately. The bus signal is supplied to the terminal board through capacitance-through-center, as Figure 3-4 shows.

The terminal board is fixed on the bottom layer of the housing in the cavity of the instrument and welded capacitance-through-center. The communication board is inserted in the terminal board, and fixed by the bolts. The Four-core cable of the instrument board is extended into the cavity of the instrument and inserted in the communication board, as the Figure 3-5 shows.

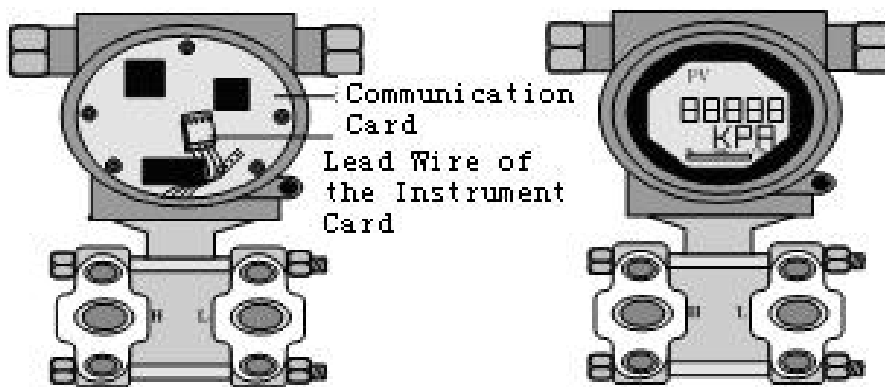

Figure 3-5 The connection of the Instrument Board

Figure 3-6 The Finished Product

After the LCD board is fixed on the communication board, the cover of the instrument can be screwed on to form a finished product, as Figure 3-6 shows.

As the core of the smart transmitter, the communication board connects the terminal board, instrument board and LCD board. The communication board is fixed in the housing behind the terminal board. And the LCD board which can be rotated in four angles is fixed on the communication board, as Figure 3-6 shows.

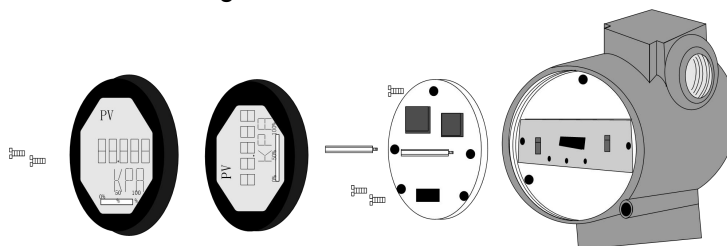

Figure 3-7 the structure of the Meter

Chapter 4 Adjusting in Workplace

4.1 Operation Instruction for Magnetic Sticks

The adjusting in workplace can be realized by inserting magnetic sticks into the holes named as “SPAN” or “ZERO”, which are on the top of the transmitter housing, shown as figure 4.1.

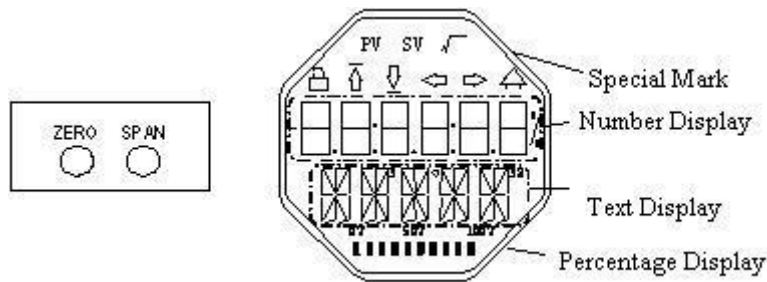

Figure 4.1 Location of magnetic sticks inserted holes and full-scale LCD

The following will show how to utilize different combinations of magnetic sticks inserting to simulate four virtual key buttons, which is good for description of adjusting in workplace. According to different functions, the four virtual key buttons are defined as Mode (M), Input adjusting ([↑], [↓]) and Confirmation ([Enter]).

- ◇ Mode (M): It can be switched in all operational modes.
- ◇ Input adjusting [↑]: Increment operation.
- ◇ Input adjusting [↓]: Degression operation
- ◇ Confirmation [Enter]: Confirmation operation.

The detailed info for operations of (M), [↑], [↓] and [Enter] are shown as following:

| Mode ⁽¹⁾ | Input adjusting ⁽¹⁾ | | Confirmation |
|---|--------------------------------|------|--|
| [M] | [↓] | [↑] | [Enter] |
| ¹⁾ Insert the magnetic sticks into “Zero” and “Span” at the same time ⁽²⁾ | Zero | Span | Insert “Zero” and “Span” for 2s, get them out ⁽²⁾ |



Notes:

- 1) Insert / Get out the magnetic sticks in Mode (M) and Input adjusting is considered as ([↑], [↓]) button operation once, also, inserting the magnetic sticks for long can be considered as long operation. In a button operation, it is suggested that user should insert the magnetic sticks for 1s, and then get it out. Otherwise, the operation can't be tested. The long operation is carried out automatically every two seconds.
- 2) In order to avoid the collision between Confirmation and Mode, when user is carrying out the confirmation operation, when the process is 100%, it means that the magnetic sticks are inserted for 2s, and then get the two magnetic sticks out to make sure the confirmation operation. When the process is 100%, the magnetic sticks are not gotten within 3s, which means to carry out switch operation. When the process is not 100%, user shall get the magnetic sticks out without operation.

4.1.1 General Adjusting Method

Following is the general adjusting method, please refer to specific description for info in detail.

In the measurement value display mode, press Mode [M] to do mode switch.

When it is displayed in mode needs to be adjusted, get out the two magnetic sticks, the present value to be adjusted will be displayed in the LCD.

Press [↑] or [↓] to adjust, after that, press [Enter] to confirm.

Press [M], switch to measurement value display mode.

Notes:

- 1. It is not necessary to confirm for some functions. After adjustment, it is saved at the same time.
- 2. If there is no button operation within 1 min (There is no magnetic sticks inserted in the two holes), it will return to normal display mode.

4.2 Adjusting for HART Smart Transmitter

In this section, we describe the adjusting steps of HART smart transmitter. By adjusting in the workplace, you can regulate zero point, unit, the upper limit and lower limit of the transmitters. The functions and operation are shown as following in detail.

| Function | Mode | Button Function | | | Function Display | Display, description |
|---------------------------|------|-----------------|-----|---------|------------------|---|
| | [M] | [↑] | [↓] | [Enter] | | |
| Measurement value display | | | | | | Display the measurement value selected in display mode 11 |
| Failure display | | | | | | Failure! When the |



| Function | Mode | Button Function | | | Function Display | Display, description | |
|----------------------------------|------|--|-----------------------|-----------------------------------|------------------|--|---|
| | [M] | [↑] | [↓] | [Enter] | | | |
| | | | | | | transmitter is in failure, it will display the reason. | |
| Lower limit | 03 | — | — | Implementation of the calibration | Fun03 LOWER | Set the lower limit of primary value range | |
| Upper limit | 04 | — | — | Implementation of the calibration | Fun04 UPPERPER | Set the upper limit of primary value range | |
| Electronic damping | 05 | Ascending | Decreasing | | Fun05 DAMP | Time constant, and the unit is second. Setting range: 0.0 to32.0 | |
| Lower limit of passive range | 06 | Pre-setting decreasing | Pre-setting ascending | Implementation | Fun06 PVLRV | Manual setting of lower limit of primary value range | |
| Upper limit of passive range | 07 | Pre-setting decreasing | Pre-setting ascending | Implementation | Fun07 PVURV | Manual setting of upper limit of primary value range | |
| Zero point of primary value | 08 | — | — | Implementation of the calibration | Fun08 ZERO | Set zero point of primary value with current value | |
| Transfer function | 10 | Decreasing | Ascending | Implementation | Fun10 FUNCT | Set linear or square root | |
| Measurement value display source | 11 | Select from varieties of possibilities | | | | Fun11 DISP | Display the expected the measurement result |
| Physical unit | 12 | Select | | | | Fun12 UNIT | Physical unit |

When the user is doing adjusting in workplace, press [M] for long, it can be switched among the functions above.

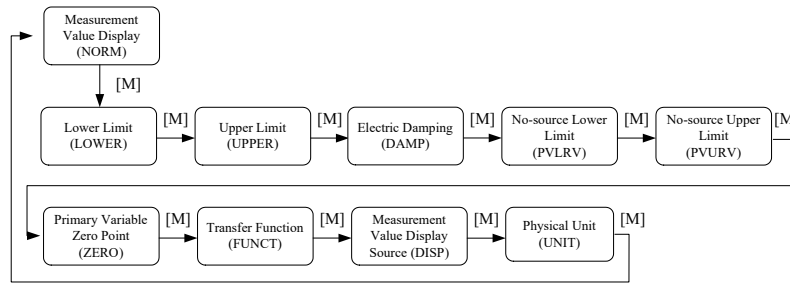

Figure 4.2 Image for adjusting function

In the status of switch mode, the digital display will display function code, i.e. “Fun 03”. The digital display will display function description as above, i.e. “LOWER”. It is not necessary to confirm the mode “10, 11, 12”. After adjustment, it is saved at the same time.

4.2.1 Measurement value display

In the function of measurement value display, it will display configuration info of DSP display blocks.

4.2.2 Error Display

In the course of local operation, the following error info may occur:

| Display | Explanation |
|---------|--|
| NumEr | Number Error |
| FNErr | Mode Number Error |
| Lock | The jump-pin is set as configuration protection. |

4.2.3 Operation steps for setting lower limit—Mode 03

The present pressure value is used to set the lower limit of primary value. Please confirm that the value input to lower limit of smart transmitter is stable.

You shall set the lower limit of primary value according to the following steps:

--Select Mode 03, the current value and unit of primary value will be displayed on LCD.

Special symbol area will display the downward arrow, indicating that it is in the lower limit currently,

--Press [Enter] to set. If the setting is successful, it will show “OK”, otherwise, it will show “Err”,

--Use [M] to do mode switch.

4.2.4 Operation steps for setting upper limit—Mode 04

The present pressure value is used to set the upper limit of primary value. Please confirm



that the value input to upper limit of smart transmitter is stable.

You shall set the upper limit of primary value according to the following steps:

- Select Mode 04, the current value and unit of primary value will be displayed on LCD. Special symbol area will display the upward arrow, indicating that it is in the upper limit currently,
- Press [Enter] to set. If the setting is successful, it will show "OK", otherwise, it will show "Err",
- Use [M] to do mode switch.

4.2.5 Operation steps for setting electronic damping—Mode 05

Setting the time constant of electronic damping, the range is from 0 to 32s.

You shall set the electronic damping according to the following steps:

- Set mode 05,
- Select damping via [↑] or [↓],
- Use [M] to do mode switch,

The damping only affects the output of analog input function block.

4.2.6 Operation steps for lower limit of passive range-- Mode 06

Passive range replacement sets lower limit of primary variable.

You shall set the lower limit of primary variable according to the following steps:

- Select mode 03, LCD will display the value and unit of current lower limit of primary variable,
- Adjust the lower limit of primary variable via [↑] or [↓],
- Press [Enter] to set. If the setting is successful, it will show "OK", otherwise, it will show "Err",
- Use [M] to do mode switch.

4.2.7 Operation steps for upper limit of passive range-- Mode 07

Passive range replacement sets upper limit of primary variable.

You shall set the upper limit of primary variable according to the following steps:

- Select mode 04, LCD will display the value and unit of current upper limit of primary variable,
- Adjust the upper limit of primary variable via [↑] or [↓],
- Press [Enter] to set. If the setting is successful, it will show "OK", otherwise, it will show "Err",
- Use [M] to do mode switch.

4.2.8 Operation steps for zero point of primary value -- Mode 08

Present pressure value is used for setting zero point of primary value. When the



transmitter is installed already and ready to operate, the outer effect such as installation location, surrounding temperature and allowable pressure related to installation (i.e. pressure column leading to pressure pipe of pressure transmitter) may cause the initial zero point to displace.

You shall calibrate zero point according to the following steps:

- Create a pressure scale,
 - Set mode 08,
 - Press [Enter] to set. If the setting is successful, it will show “OK”, otherwise, it will show “Err”,
 - Use [M] to do mode switch.
- Switch to pressure value display mode, 0 will be in display area.

4.2.9 Operation steps for setting transfer function -- Mode 10

Setting current output mode: Linear output (for pressure measurement) or square root output (for flow measurement).

You shall set transfer function according to the following steps:

- Select mode 10, LCD will display type of current transfer function.
- Select the type of transfer function via [↑] or [↓],
- Use [M] to do mode switch.

4.2.10 Operation steps for setting measurement value display type-- Mode 11

In this mode, you shall select the value to be displayed.

You shall select the source of measurement value according to the following steps:

- Select mode 11, LCD will display value and description of present display source,
- Select the display source of measurement value via [↑] or [↓],
- Use [M] to do mode switch.

Following is display source of supported measurement value.

| Measurement value display type | LCD display description |
|--|-------------------------|
| [0] Primary variable value output | PV |
| [1] Second variable value output | SV |
| [2] Primary variable current output | CU |
| [3] Primary variable percentage output | PN |
| [4] Primary variable and current circle output | LOOP |

4.2.11 Operation steps for primary variable unit-- Mode 12

In this mode, you shall modify the primary variable unit.

You shall select the source of measurement value according to the following steps:

- Select mode 12, LCD will display present unit identifier and the corresponding unit descriptions,



- Select a unit via [↑] or [↓],
- Use [M] to do mode switch.

4.3 Adjusting for FF Smart Transmitter

In this section, we describe the adjusting steps of FF smart transmitter. By adjusting in the workplace, you can regulate zero point, unit, the upper limit and lower limit of the transmitters. The functions and operation are shown as following in detail.

| Function | Mode | Button Function | | | Function Display | Display, description |
|-----------------------------|------|-----------------------|------------------------|-----------------------------------|------------------|--|
| | [M] | [↑] | [↓] | [Enter] | | |
| Measurement value display | | | | | | Display the configuration info displayed by DSP display block |
| Failure display | | | | | | Failure! When the transmitter is in failure, it will display the reason. |
| Zero point of primary value | 15 | — | — | Implementation of the calibration | Fun15 ZERO | For pressure, differential pressure, flow,. The liquid level transmitter discharges to vacuum, the absolute pressure transmitter is in vacuum. The unit for measured value is pressure unit. |
| Lower limit | 16 | Pre-setting ascending | Pre-setting decreasing | Implementation of the calibration | Fun16 LOWER | Set the lower limit of characteristic curve |
| Upper limit | 17 | Pre-setting ascending | Pre-setting decreasing | Implementation of the calibration | Fun17 UPPERPER | Set the upper limit of characteristic |



| Function | Mode | Button Function | | | Function Display | Display, description |
|----------------------------------|------|--|-----------------------|-----------------------------------|------------------|--|
| | [M] | [↑] | [↓] | [Enter] | | |
| | | | | | | curve |
| Electronic damping | 05 | Ascending | Decreasing | | Fun05 DAMP | Time constant, and the unit is second. Setting range: 0.0 to32.0 |
| Lower limit of passive range | 06 | Pre-setting decreasing | Pre-setting ascending | Implementation | Fun06 PVLRV | Manual setting of lower limit of primary value range |
| Upper limit of passive range | 07 | Pre-setting decreasing | Pre-setting ascending | Implementation | Fun07 PVURV | Manual setting of upper limit of primary value range |
| Zero point of primary value | 08 | — | — | Implementation of the calibration | Fun08 ZERO | Set zero point of primary value with current value |
| Transfer function | 10 | Decreasing | Ascending | Implementation | Fun10 FUNCT | Set linear or square root |
| Measurement value display source | 11 | Select from varieties of possibilities | | | Fun11 DISP | Display the expected the measurement result |
| Physical unit | 12 | Select | | | Fun12 UNIT | Physical unit |

When the user is doing adjusting in workplace, press [M] for long, it can be switched among the functions above.

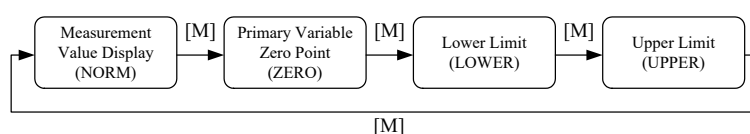

Figure 4.3 Image for adjusting function

4.3.1 Measurement value display

In the function of measurement value display, it will display configuration info of DSP



display blocks.

4.3.2 Error Display

In the course of local operation, the following error info may occur:

| Display | Explanation |
|---------|--|
| NumEr | Number Error |
| FNErr | Mode Number Error |
| Lock | The jump-pin is setting as configuration protection. |

4.3.3 Operation steps for zero point of primary value -- Mode 15

When the transmitter is installed already and ready to operate, the outer effect such as installation location, surrounding temperature and allowable pressure related to installation (i.e. pressure column leading to pressure pipe of pressure transmitter) may cause the initial zero point to displace.

You shall calibrate zero point according to the following steps:

- Create a pressure scale,
- Set mode 15,
- Press [Enter] to set. If the setting is successful, it will show "OK", otherwise, it will show "Err",
- The calibration is successful, return to the measurement value display mode. 0 will be in display area.

4.3.4 Operation steps for lower limit of range-- Mode 16

In this mode, you shall modify the slope of characteristic curve. The characteristic curve is rolling around the high setting point, which replaces the zero point calibration (Mode 08).

You shall implement the calibration of lower limit according to the following steps:

- Select mode 16, LCD will display the calibrated process value last time and related unit,
- If you just would like to check the info, press [M] to do mode switch. Otherwise, you may use the reference pressure,
- Input the reference pressure value starting from this point via [↑] or [↓],
- Press [Enter] to set. If the setting is successful, it will show "OK", otherwise, it will show "Err",
- Use [M] to do mode switch.

4.3.5 Operation steps for upper limit of range-- Mode 17

In this mode, you shall modify the slope of characteristic curve. The characteristic curve is rolling around the low setting point.

You shall implement the calibration of upper limit according to the following steps:

- Select mode 17, LCD will display the calibrated process value last time and related unit,
- If you just would like to check the info, press [M] to do mode switch. Otherwise, you may



- use the reference pressure,
- Input the reference pressure value starting from this point via [↑] or [↓],
- Press [Enter] to set. If the setting is successful, it will show “OK”, otherwise, it will show “Err”,
- Use [M] to do mode switch.

4.4 Adjusting for PA Smart Transmitter

In this section, we describe the adjusting steps of PA smart transmitter. By adjusting in the workplace, you can regulate bus address, display variable type, point position, zero point, unit, the upper limit and lower limit of the transmitters,etc. The functions and operation are shown as following in detail.

| Function | Mode | Button Function | | | Function Display | Display, description |
|----------------------------------|------|--------------------------------------|------------|----------------|------------------|---|
| | [M] | [↑] | [↓] | [Enter] | | |
| Measurement value display | | | | | | Display the measurement value displayed in Mode 11 |
| Failure display | | | | | | Failure! When the transmitter is in failure, it will display the reason. |
| Electronic damping | 05 | Ascending | Decreasing | | Fun05 DAMP | Time constant, and the unit is second. Setting range: 0.0 to32.0 |
| Measurement value display source | 11 | Select from various of possibilities | | | Fun11 DISP | Display the expected the measurement result |
| Physical unit | 12 | Select | | | Fun12 UNIT | Physical unit |
| Bus address | 13 | Ascending | Decreasing | Implementation | Fun13 ADDR | User address from PROFIBUS (0---126) |
| Point | 14 | Modify | | | Fun14 DECPT | Point position in display |



| Function | Mode | Button Function | | | Function Display | Display, description |
|-----------------------------|------|-----------------------|------------------------|-----------------------------------|------------------|--|
| | [M] | [↑] | [↓] | [Enter] | | |
| | | | | | | area |
| Zero point of primary value | 08 | — | — | Implementation of the calibration | Fun08 ZERO | For pressure, differential pressure, flow,. The liquid level transmitter discharges to vacuum, the absolute pressure transmitter is in vacuum. The unit for measured value is pressure unit. |
| Lower limit of range | 16 | Pre-setting ascending | Pre-setting decreasing | Implementation | Fun16 LOWER | Setting the lower limit of characteristic curve |
| Upper limit of range | 17 | Pre-setting ascending | Pre-setting decreasing | Implementation | Fun17 UPPER | Setting the upper limit of characteristic curve |
| Lower limit of input range | 18 | Pre-setting ascending | Pre-setting decreasing | Implementation | Fun18 IN 0% | No-source setting the lower limit of input range |
| Upper limit of input range | 19 | Pre-setting ascending | Pre-setting decreasing | Implementation | Fun19 IN 100% | No-source setting the upper limit of input range |
| Lower limit of output range | 20 | Pre-setting ascending | Pre-setting decreasing | Implementation | Fun20 OUT 0% | No-source setting the lower limit of output range |
| Upper limit of output range | 21 | Pre-setting ascending | Pre-setting decreasing | Implementation | Fun20 OUT100% | No-source setting the upper limit of output range |

Press [M] for long, it can be switched among the functions above.

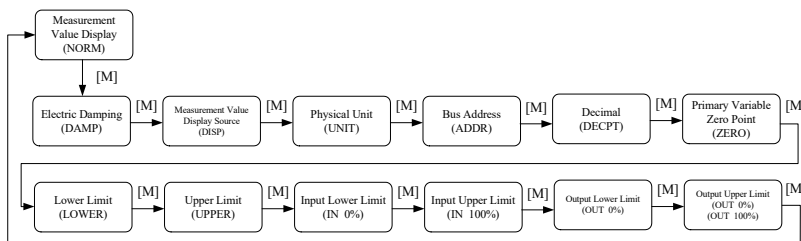

Figure 4.4 Image for adjusting function

4.4.1 Measurement value display

In the function of measurement value display, it will display the measurement value selected in Mode 11. The physical unit is set in Mode 12. Point position is set in Mode 14.

4.4.2 Error Display

In the course of local operation, the following error info may occur:

| Display | Explanation |
|---------|--|
| NumEr | Number Error |
| FNErr | Mode Number Error |
| UNErr | Unit doesn't match |
| Lock | The jump-pin is setting as configuration protection. |

4.4.3 Operation steps for setting electronic damping -- Mode 05

It is about setting time constant of electrical damping, the range is from 0 to 32s.

You shall set electrical damping according to the following steps:

- Set mode 05,
- Select damping via [↑] or [↓],
- Use [M] to do mode switch,

The damping only affects the output of input function block of analog parameters.

4.4.4 Operation steps for setting measurement value display source--Mode 11

In this mode, you may select the value to be displayed. In SIMATIC PDM, it is the parameter of "Transmitter Type".

You shall select the display source of measurement value according to the following steps:

- Set mode 11,
- Select the display source of measurement value via [↑] or [↓],
- Use [M] to do mode switch.

In Mode 12, the distributed physical unit depends on the display source of measurement



value.

Following is the supportive measurement value display source.

| Display source of measurement value | Auxiliary info of LCD |
|--|-----------------------|
| [0]Primary value output of pressure transducer block | PRIM |
| [1]Second value output of pressure transducer block | SEC1 |
| [2]AI function block output | AIOUT |
| [3]Sensor original value of pressure transducer block | SENS |
| [4]Sensor temperature value of pressure transducer block | TEMP |
| [5]TOT function block output | TOTAL |

4.4.5 Operation steps for setting physical unit--Mode 12

The physical unit can be set by selecting in the list. The selected unit depends on the display source of measurement value (Mode 11).

You shall set the physical unit according to the following steps:

--Set mode 12. When the mark of present value appears in the display area, the related text will be in the unit display area.

--Select the a unit via [↑] or [↓],

--Use [M] to do mode switch.

Following is a list about physical unit can be used in every measurement type:

Pressure Unit:

| Code | Unit | Code | Unit | Code | Unit |
|------|------|------|-------------------------|------|-------------------------|
| 1130 | Pa | 1140 | atm | 1150 | mmH ₂ O(4℃) |
| 1131 | GPa | 1141 | psi | 1151 | mmH ₂ O(68℃) |
| 1132 | MPa | 1142 | psia | 1152 | ftH ₂ O |
| 1133 | KPa | 1143 | psig | 1153 | ftH ₂ O(4℃) |
| 1134 | mPa | 1144 | g/cm ² | 1154 | ftH ₂ O(68℃) |
| 1135 | μPa | 1145 | kg/cm ² | 1155 | inHg |
| 1136 | hPa | 1146 | inH ₂ O | 1156 | inHg(0℃) |
| 1137 | bar | 1147 | inH ₂ O(4℃) | 1157 | mmHg |
| 1138 | mbar | 1148 | inH ₂ O(68℃) | 1158 | mmHg(0℃) |
| 1139 | torr | 1149 | mmH ₂ O | | |

Volume Unit:

| Code | Unit | Code | Unit | Code | Unit |
|------|-----------------|------|-------------------|------|-------|
| 1034 | m ³ | 1041 | hL | 1048 | GAL |
| 1035 | dm ³ | 1042 | IN ³ | 1049 | ImGAL |
| 1036 | cm ³ | 1043 | FT ³ | 1050 | BUSHL |
| 1037 | mm ³ | 1044 | Yd ³ | 1051 | bbl |
| 1038 | L | 1045 | mile ³ | 1052 | bblli |
| 1039 | cL | 1046 | Pint | | |
| 1040 | mL | 1047 | Quart | | |

Weight Unit:

| Code | Unit | Code | Unit | Code | Unit |
|------|------|------|------|------|------|
| 1088 | KG | 1091 | Mg | 1094 | lb |
| 1089 | G | 1092 | T | 1095 | STon |
| 1090 | mg | 1093 | oz | 1096 | LTon |

Weight Flow Unit:



| Code | Unit | Code | Unit | Code | Unit |
|------|-------|------|-------|------|------|
| 1318 | G/S | 1326 | T/S | 1334 | ST/S |
| 1319 | G/min | 1327 | T/min | 1335 | ST/m |
| 1320 | G/h | 1328 | T/h | 1336 | ST/h |
| 1321 | G/d | 1329 | T/d | 1337 | ST/d |
| 1322 | KG/s | 1330 | lb/S | 1338 | LT/S |
| 1323 | KG/m | 1331 | lb/m | 1339 | LT/m |
| 1324 | KG/h | 1332 | lb/h | 1340 | LT/h |
| 1325 | KG/d | 1333 | lb/d | 1341 | LT/d |

Volume Flow Unit:

| Code | Unit | Code | Unit | Code | Unit |
|------|-------|------|-------|------|-------|
| 1347 | m3/S | 1354 | L/d | 1363 | GPM |
| 1348 | m3/m | 1355 | ML/d | 1364 | GAL/h |
| 1349 | m3/h | 1356 | CFS | 1365 | GAL/d |
| 1350 | m3/d | 1357 | CFM | 1371 | bbI/S |
| 1351 | L/S | 1358 | CFH | 1372 | bbI/m |
| 1352 | L/min | 1359 | CFD | 1373 | bbI/h |
| 1353 | L/h | 1362 | GAL/S | 1374 | bbI/d |

4.4.6 Operation steps for setting bus address--Mode 13

In mode 13, you shall set the user address of the device in PROFIBUS. The admitted range is from 0 to 126.

You shall set the PROFIBUS address according to the following steps:

- Set mode 13. The present user address will be displayed in measurement value display area.
- Press [Enter] to set. If the setting is successful, it will show "OK", otherwise, it will show "Err",
- Use [M] to do mode switch.

4.4.7 Operation steps for setting point--Mode 14

The measurement value can display the precision of 5 bits. You shall set the point position according to the following steps:

- Set mode 14. The present point format will be displayed in measurement value display area.
- Select the expected display format via [↑] or [↓],
8.88888 88.8888 888.888 8888.88 88888.8 888888
- Use [M] to do mode switch.

4.4.8 Operation steps for zero point of primary value -- Mode 15

When the transmitter is installed already and ready to operate, the outer effect such as installation location, surrounding temperature and allowable pressure related to installation (i.e. pressure column leading to pressure pipe of pressure transmitter) may cause the primary zero point to displace.

You shall calibrate zero point according to the following steps:

- Create a pressure scale,



- Set mode 15,
- Press [Enter] to set. If the setting is successful, it will show "OK", otherwise, it will show "Err",
- The calibration is successful, it will return to display mode of measurement value. 0 will be in display area.

4.4.9 Operation steps for lower limit of range-- Mode 16

In this mode, you shall modify the slope of characteristic curve. The characteristic curve is rolling around the high setting point, which replaces the zero point calibration (Mode 08).

You shall implement the calibration of lower limit according to the following steps:

- Select mode 16, LCD will display the calibrated process value last time and related unit,
- If you just would like to check the info, press [M] to do mode switch. Otherwise, you may use the reference pressure,
- Input the reference pressure value starting from this point via [↑] or [↓],
- Press [Enter] to set. If the setting is successful, it will show "OK", otherwise, it will show "Err",
- Use [M] to do mode switch.

4.4.10 Operation steps for upper limit of range-- Mode 17

In this mode, you shall modify the slope of characteristic curve. The characteristic curve is rolling around the low setting point.

You shall implement the calibration of upper limit according to the following steps:

- Select mode 17, LCD will display the calibrated process value last time and related unit,
- If you just would like to check the info, press [M] to do mode switch. Otherwise, you may use the reference pressure,
- Input the reference pressure value starting from this point via [↑] or [↓],
- Press [Enter] to set. If the setting is successful, it will show "OK", otherwise, it will show "Err",
- Use [M] to do mode switch.

4.4.11 Operation steps for lower limit of input range-- Mode 18

In this mode, you shall set the lower limit of input range.

You shall do implement the calibration of lower limit of input range according to the following steps:

- Select mode 18, LCD will display the calibrated process value last time and related unit,
- Input the reference value starting from this point via [↑] or [↓],
- Press [Enter] to set. If the setting is successful, it will show "OK", otherwise, it will show "Err",
- Use [M] to do mode switch.



4.4.12 Operation steps for upper limit of input range-- Mode 19

In this mode, you shall set the upper limit of input range.

You shall do implement the calibration of upper limit of input range according to the following steps:

- Select mode 19, LCD will display the calibrated process value last time and related unit,
- Input the reference value starting from this point via [↑] or [↓],
- Press [Enter] to set. If the setting is successful, it will show “OK”, otherwise, it will show “Err”,
- Use [M] to do mode switch.

4.4.13 Operation steps for lower limit of output range-- Mode 20

In this mode, you shall set the lower limit of input range.

You shall do implement the calibration of lower limit of input range according to the following steps:

- Select mode 20, LCD will display the calibrated process value last time and related unit,
- Input the reference value starting from this point via [↑] or [↓],
- Press [Enter] to set. If the setting is successful, it will show “OK”, otherwise, it will show “Err”,
- Use [M] to do mode switch.

4.4.14 Operation steps for upper limit of output range-- Mode 21

In this mode, you shall set the upper limit of input range.

You shall do implement the calibration of upper limit of input range according to the following steps:

- Select mode 21, LCD will display the calibrated process value last time and related unit,
- Input the reference value starting from this point via [↑] or [↓],
- Press [Enter] to set. If the setting is successful, it will show “OK”, otherwise, it will show “Err”,
- Use [M] to do mode switch.

4.5 Return instrument data to factory data

Returning instrument data to factory data is a special operation, there is no function code.

After the operation, all the configured data will disappear and will return to factory data.

Please pay more attention when you do like this.

You may return instrument data to factory data according to the following steps:

- Turn off the power supply with instrument,
- Insert two magnetic bars into “Zero” and “Span” holes at the same time,
- Turn on the power supply for instrument, the LCD will display “RST?”,
- If you would like to return instrument data to factory data, get the two magnetic bars out,

and then insert two magnetic bars, when the process is 100%, get the two magnetic bars out again, the LCD will display “R_OK”, which means the return is successful.

-- If you wouldn't like to return instrument data to factory data, get the two magnetic bars out, and wait for 5 seconds, it will back to normal.

Notes:

For FF smart transmitter or PA smart transmitter, following the steps above, if there is RAT jump-pin, it will return to factory data without “RST”.

When the process is not 100%, if you get the two magnetic bars out, it may cancel the operation of returning instrument data to factory data.

Chapter 5 Configuration of HART Smart Transmitter

5.1 Topologic Connection

The connection of the HART smart transmitter includes Point-to-Point connection and Multi-Point connection.

- **Point-to-Point(Figure 5-1)**

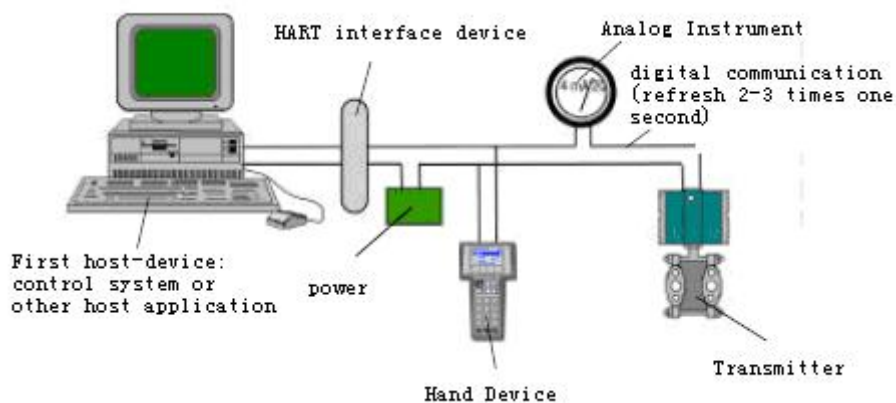

Figure 5-1 Point-to-Point Connection

Feature:

- 1) Can be connected to the control system above through common AI input module and HART communication device,

- 2) Mixed use of the analog and digital communication,
 - 3) The device address is 0.
- **Multi-Point(Figure 5-2)**

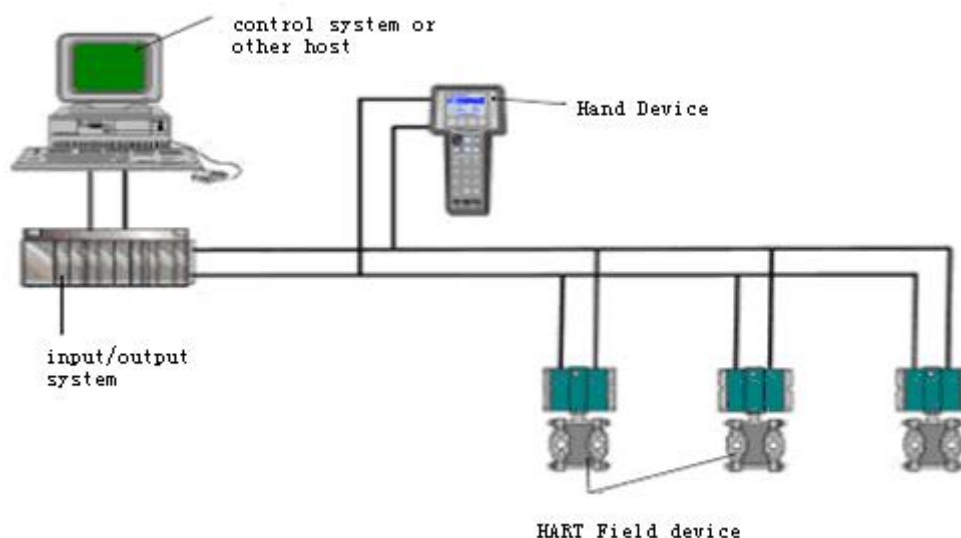

Figure 5-2 Multi-Point Connection

Feature:

- 1) Can be connected to the control system above through HART communication device;
- 2) Only use HART system digital function , and the fixed current on wire is 4mA;
- 3) Support 15 devices in short address mode.

5.2 Function Configuration

Smart transmitter can be configured by the HART configuration software, including three functions:

- 1) Basic information configuration: configure the basic information of device online , including tag, address, date, assemble number and so on;
- 2) Configurable information configuration: configure the configurable information of device online, including primary variable range, damp and so on;
- 3) Current calibration: Can calibrate 4 ~ 20mA current, using two-point calibration (4mA and 20mA), and user can set fixed current output mode, to test current accuracy.

- **Configuration environment**

- 1) PC with serial, the OS is Windows 2000 or Windows XP;
- 2) HART Modem and serial wire;
- 3) Matching resistance 250~550 ohm;
- 4) Standard pressure source.



- **Basic information configuration**

Through the dialog of basic information, the basic information of the smart transmitter can be read or modified, including device address, message, description, date, assemble number, alarm, write protection, manufacturer ID, device type, device ID, long address and version info(Figure 5-3) .

After information modification, click the “Apply” button to download it into device. If not send successfully, the information of the device will be not modified. If give up modification, select the “exit” button to exit basic information operation.

- 1) The maximum length of the tag is 8 characters;
- 2) The maximum length of the description is 16 characters;
- 3) Message can be input 32 characters at most;
- 4) The address selection range is 0~15;
- 5) Assemble number is 6 characters at most.

- **Configurable information configuration**

Through the dialog of configuration information, the configuration information of smart transmitter can be read or modified, including the value and unit of the primary variable and second variable (pressure and temperature), current value, percentage, output info of the primary variable (damp value, unit, upper limit of the range, range lower limit, output transfer function), sensor info (serial number, upper limit, lower limit, minimum range, unit) and so on (Figure 5-4) .

Primary variable unit configuration: The vary of the primary variable has a direct influence on the variable related to unit, such as the upper/lower limit of range, the upper/lower limit of sensor and minimum span. When you modify the unit, you can't modify the value of the upper/lower limit of primary variable range at the same time.

Damp configuration: The range is 0~15 s.

Calibrate the lower limit of range: Make the measurement primary variable value as the lower limit of range, and the range should be not changed (the upper limit of range is modified accordingly). If the adjustment of the upper limit of range exceeds the upper limit of sensor range, make the upper limit of sensor as the adjusted upper limit of range, and then the range is changed sequencely. Calibrate the upper limit of range : Make the measurement primary variable value as the upper limit of range, and the lower limit of range should not be changed, so the range is changed. if the adjustment of the upper limit of range exceeds the upper limit of sensor range, make the upper limit of sensor as the adjusted upper limit of range. Calibrate the zero of the primary variable: Calibrate the zero displacement of primary variable due to installation location.



| | | | |
|-----------------------|--------------|---------------------------|----------|
| PV | -9.374 | Set PV Upper Range Value | |
| Unit | kPA | Set PV Lower Range Value | |
| Temperature value | 20.875 °C | Set Primary Variable Zero | |
| Current Value | 3.900 mA | Set Range Value | |
| Percentage | -5.038 % | | |
| PV Output Information | | Sensor Information | |
| Damping Value | 0.0 秒 (0-15) | Serial Number | 000000 |
| Unit | kPA | Upper Range Value | 186.000 |
| Upper Range Value | 186.000 | Lower Range Value | -186.000 |
| Lower Range Value | 0.000 | Minimal Span | 1.860 |
| Transfer Function | linear | Unit | kPA |
| Apply | | Exit | |

Figure 5-4 Dialog of configuration information6) Calibrate the range: After the displacement, you should calibrate the upper/lower limit of range, following are the steps:

- ① Add standard pressure of the range lower limit to transmitter, when the pressure is stable, select the calibration point “lower range”, as Figure 5-5 shows. And then click the button “get current value”, the calibration data is displayed in “adjustment value”. Complete the calibration by clicking the button “download”. Now the practical pressure value is the pressure value of range lower limit, and the current output is 4mA.

Set Range Value

Set Point: Lower Ran (dropdown) Get Current Value

Adjustment Value: [] Download

Figure 5-5 Calibration of range lower limit

- ② Add practical pressure of the up limit of the range on the Transmitter, select the calibration point of “up-limit of range”, Add standard pressure of the range upper limit to transmitter, when the pressure is stable, select the calibration point “upper range”, as Figure 5-6 shows. And then click the button “get current value”, the calibration data is displayed in “adjustment value”. Complete the calibration by clicking the button “download”. Now the practical pressure value is the pressure value of range upper limit, and the current output is 4mA.

Set Range Value

Set Point: Upper Ran (dropdown) Get Current Value

Adjustment Value: [] Download

Figure 5-6 Calibration of range upper limit

- **Current calibration and fixed current output**

User can calibrate the analog output current 4mA and 20mA and output fixed current. In

the operation, the rolling address of the smart transmitter must be 0. And other rolling addresses will prompt error message “in multi-point mode”. In addition, an ammeter, with the 5 1/2 digit precision, should be series-wounded in the output loop of the smart transmitter.

Calibrate 4mA and 20mA current : In Figure 5-7, select the current value needed to calibrate, when the output current is stable, and input the practical value of current (the value of the ammeter) to the edit “adjustment value”, and then click the button “apply”. Note whether the output current is satisfied to the requirements, if not, follow the steps above to adjust again.

Fixed current output: In Figure 5-7,input the value of the current the smart transmitter will be fixed on, to “fixed current value”, and click the button “enter/exit fixed current mode” to enter or exit the mode of fixed current output. The text of the button can display “exit fixed current mode” and “enter fixed current mode” in turn, to tell users what to do.

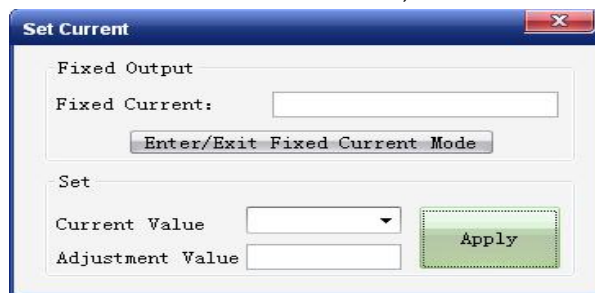

Figure 5-7 Calibrate current

- **Saturable fixed output (Set by manufacturer, do not calibrate)**

In the run of the HART smart transmitter, compare the value of the primary variable and range upper/lower limit of the of the primary variable continuously. When the value of the primary variable exceeds the range of the primary variable, the smart transmitter will output fixed current to indicate that the value of the primary variable is exceeded. When it is over the upper limit, the smart transmitter output fixed current **20.8mA**; When it is less than the lower limit, output **3.9mA**.

5.3 Jump-pin Configuration

HART smart transmitter has two hardware jumpers, as Figure 5-8 shows. The three points on bottom are failure alarm current setting jumpers, and the top three points are calibration protection setting jumpers.

Failure Alarm Current Jumper

HART smart transmitter has self-diagnosis function. When a failure is tested out, the transmitter will output alarm current automatically. The alarm current mode depends on failure alarm current jumper setting on the right side of the communication board. When the jumpers are in the two points marke with “Hi”, it will be the high level alarm ($\geq 21.75\text{mA}$). When the jumpers are in the two points marke with “Lo”, it will be the low level alarm ($\leq 3.75\text{mA}$).

Calibration Protection Setting Jumper

HART smart transmitter supplies the calibration protection jumper setting or not, shown as Figure 5-8. When the jumper is at the right side of two points marked with “WRD”, it will be the calibration protection. And in that time, the HART smart transmitter does not allow any operation about modifying device configuration. When the jumper is at the left side, the HART smart transmitter allows the operation about modifying device configuration.

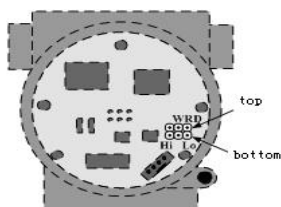

Figure 5-8 HART Smart Transmitters Hardware Jumpers

Chapter 6 Configuration of FF Smart Transmitter

6.1 Topologic Connection

FF transmitter supports many net topologies shown as Figure 6-1. . shows the bus connection of FF instrument is shown in Figure 6-2, in order to ensure the bus signal quality, the terminal matching resistances should be connected to the 2 ends of the bus. The bus maximum length is 1900m, with a repeater, the length can be extended to 10 kilometers.

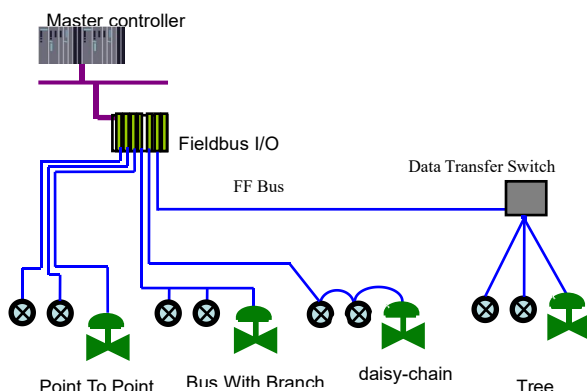

Figure 6-1 the Topology of FF Bus

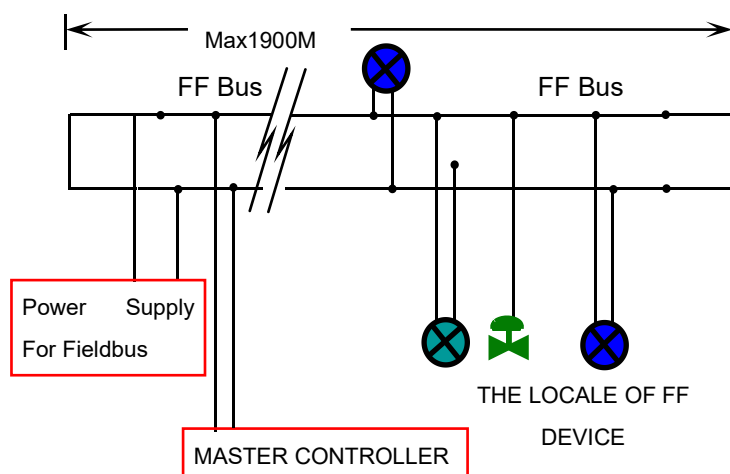

Figure 6-2 FF Bus Connection

6.2 Function Block

FF smart transmitters carry out the FF standard function blocks, shown in the table below. Please refer to related FF protocol document for detailed information about configuration methods of function blocks.

| Function Block name | Description |
|---------------------|---|
| RES | Resource block is used to describe the device identity in the field, such as device name, manufacture, serial number. There is no input or output parameter in the resource block. Generally, there is only one resource block for each device. |
| TRD | Transducer block is used to read sensor hardware data, or write the data in the field to related hardware. Transducer block includes the info such as range, sensor type, linearization, I/O data, etc. |
| DSP | DSP block is used to configure display info in LCD. |
| PID | PID function block has the function of PID control and setting point adjustment, process value(PV) filtering and alarm, output tracking, etc. |
| AI | Analog input function block is used to achieve transducer block input data and transfer to other function blocks, has the function of range conversion, square root, cut mantissa, etc. |
| LLAG | LLAG function block is used for feedforward control. |
| RA | RA function block is used to control the proportion between inputs. |

6.3 Function Configuration

Smart transmitter supports FF Configuration Software and NCS4000 Configuration Software from Microcyber, NI-FBUS Configurator from NI, DeltaV from Rosemont and other general FF Configuration Software for configuration. The following example which uses the Microcyber's FF HMI explains the configuration of the Smart transmitter. Take FF Configuration Software as an example to explain the configuration method:

- **Configuration environment**

- 1) PC with Windows2000 or Windows XP;
- 2) NCS3000 gateway device, H1 bus power, H1 terminator

- 3) FF Configuration Software;
- 4) Standard pressure source;

Primary variable zero configuration Add operating pressure value at zero point to transmitter, set as “Sensor Zero Trim” (shown as Figure 6.3) via transducer block calibration parameter ENABLE_LIN_CURVE, to finish the sensor zero calibration. Read the PRIMARY_VALUE of transducer block, it would be zero.

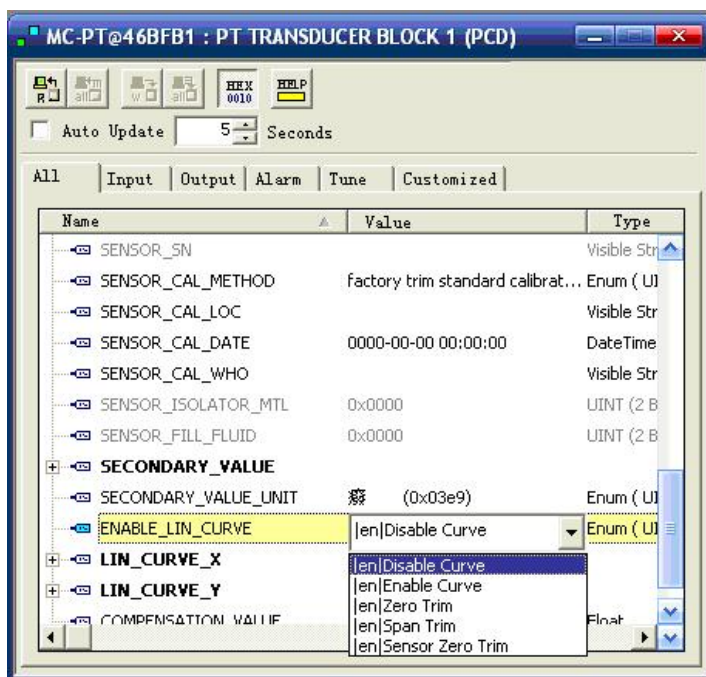

Figure 6-3 ENABLE_LIN_CURVE configuration

Lower range limit configuration Add operating pressure value at lower range limit to transmitter, set as “Zero Trim” via transducer block calibration parameter ENABLE_LIN_CURVE, to finish lower range limit calibration, set present sensor output as primary variable lower limit, read the XD_SCALE of AI function block, it should be the same as the present output.

- **Upper range limit configuration**

Add operating pressure value at higher range limit to transmitter, set as “Span Trim” via transducer block calibration parameter ENABLE_LIN_CURVE, to finish full range calibration, set present sensor output as primary variable upper limit, read the XD_SCALE of AI function block, it should be the same as the present output.

- **Secondary linearity adjusting**

User can achieve instrument second linearization calibration all by himself via transducer block parameters LIN_CURVE_X and LIN_CURVE_Y. The steps shown as following:

- (1) The intelligent transmitter supports 6 calibration points input, they are parameters of transducer block. For LIN_CURVE_Y array, user should write pressure value to calibrate into array and select the unit sequentially. For example, for 3 points calibration, user should choose 10Kpa, 20Kpa, 30Kpa as the calibration points, and then write them to LIN_CURVE_Y array, shown as Figure 6-4:

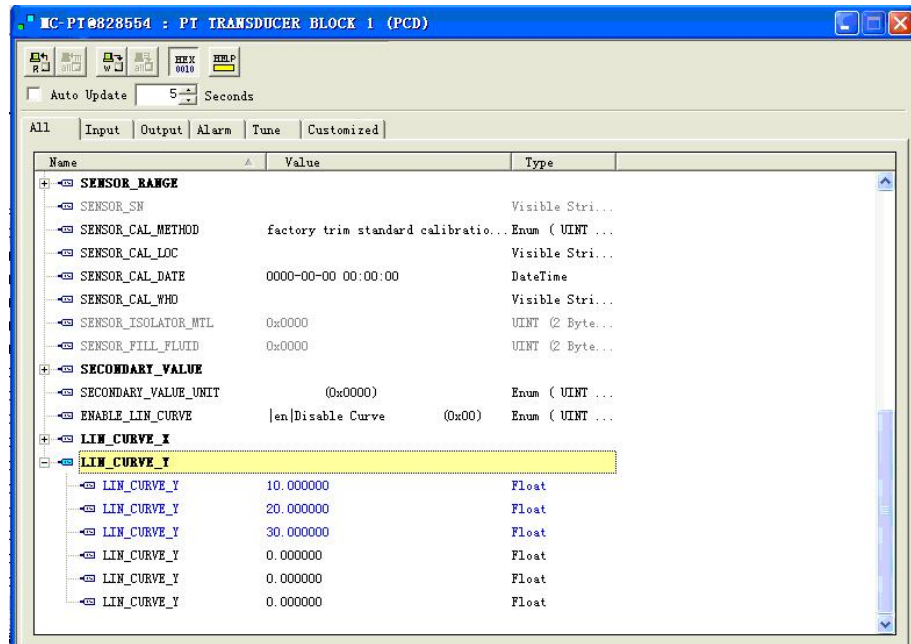
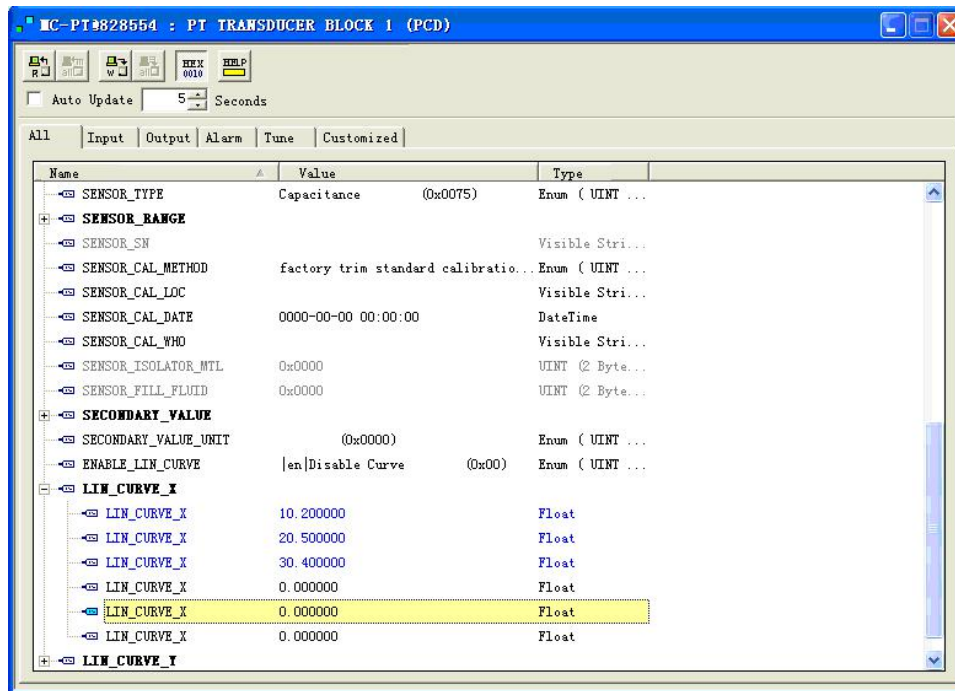

Figure 6-4 LIN_CURVE_Y configuration

- (2) Input standard pressure via pressure source, and open related transducer block in configuration software, read separately PRIMARY_VALUE, and write the data to LIN_CURVE_X array. For example, if write the read data 10.2 , 20.5 , 30.4 to LIN_CURVE_X array, shown as Figure 6-5, all the calibration is finished.



1)

Figure 6-5 LIN_CURVE_X configuration

(3) User sets the transducer block parameter ENABLE_LIN_CURVE as “Enable Curve”, to ensure the smart transmitter works in normal after the calibration.

● **LCD display configuration**

In default, smart transmitter displays transducer block PRIMARY_VALUE from the first channel shown as Figure 6-6. If the user would like to display other parameter info of function block, they can configure the parameter according to the following steps (X means 1, 2, 3, 4. There are 4 groups of parameters in total, each group can be configured separately. The smart transmitter will display the info of 4 groups cyclely). If there is a configuration error, the smart transmitter will only display CONFIG_ERR. Write the display function block status as OOS before right configuration, and write as AUTO after configuration, which makes the configuration is effective..

- 1) BLOCK_TAG_X: This parameter defines function block name which to display. For example, user would like to display a certain PT-AI1 parameter, he should configure the BLOCK_TAG_X at first, define parameter value as PT-AI1. Notes: It must be 32 bytes, otherwise padded the 'space' align 32 byte. For example, if wants to input “PT-AI1” the following should be wrote in HMI: “PT-AI1”. BLOCK_TAG_X requires input is 32 bytes. If it is less than 32 bytes, it shall be added, For example, you should write “PT-AI1” in configuration software for the “PT-AI1” mention above.
- 2) RELATIVE_INDEX_X: This parameter defines display function block parameter index. For example, if the user would like to display PT-AI1 output value, define the parameter as 8 (The index of PT_AI1’s OUT parameter is 8). More information can be referred to in the part of FF fieldbus functions block protocol.
- 3) SUB_INDEX_X: This parameter defines display function block parameter index



(if exist). For example, if the user would like to display PT-AI1 output value, define the parameter as 8 and define SUB_INDEX_X as 2 (The sub index of OUT parameter value is 2).

- 4) MNEMONIC_X: This parameter is used to display parameter name, it can be input by user at random, but it can't be longer than 16 bytes.
- 5) DECI_PNT_NUMB_X: This parameter defines display value precision. For example, you should define the value as 3 if you would like to display the last 3 bits after the decimal.
- 6) ACTIVE_X: This parameter value is as FALSE or TRUE, after finish setting other parameters, set this parameter to TURE to activation all configuration. Write it as TRUE when other parameters are configured already, therefore, you can active all the configured parameters and the transmitter will display all the related parameter info in the group.

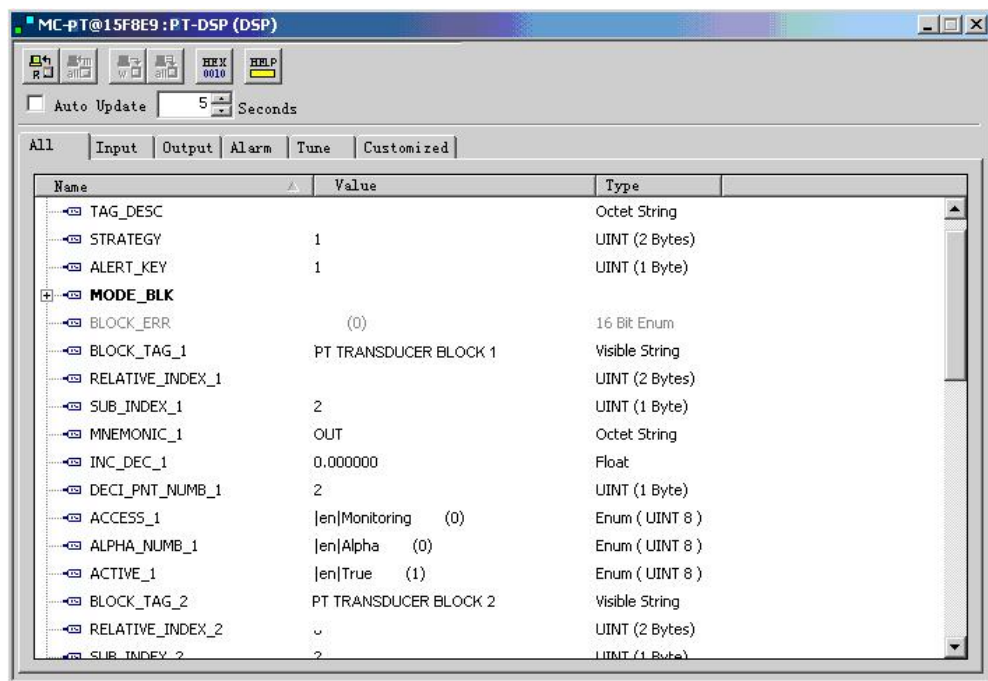

Figure 6-6 the display parameter configuration

6.4 Jumper-pin Configuration

There are 3 hardware jumpers in FF smart transmitter shown as Figure 6-7.

SIM Jumper: Simulation jumper can achieve simulation function.

WP Jumper: Write protection jumper can refuse any write operation for FF smart transmitter, which can avoid the vicious modification for instrument data.

RST Jumper: Reset jumper will reset the transmitter data back to factory. Please make the transmitter powered off, insert the jumper to RST, and then power the transmitter on, the data will be back to factory data.

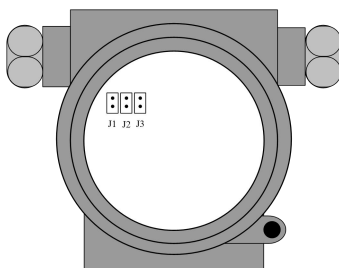

Figure 6-7 FF Smart transmitters jumper

Chapter 7 Configuration of PA Smart Transmitter

7.1 Topology Connection

- **Transmitter topology connection**

A PROFIBUS PA transmitter supports many net topologies shown as Figure 7-1. . shows the bus connection of PA instrument is shown in Figure 7-2, in order to ensure the bus signal quality,the terminal matching resistances should be connected to the 2 ends of the bus. The bus maximum length is 1900m, with a repeater, the length can be extended to 10 kilometers.

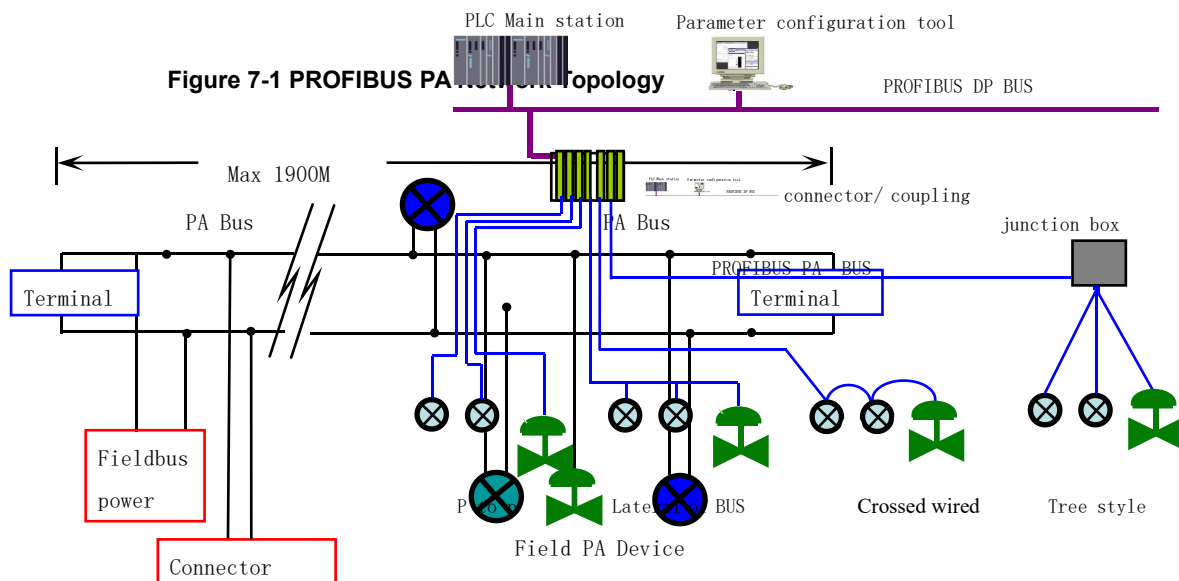

Figure 7-2 PROFIBUS PA BUS CONNECTIONS

7.2 Function Block

PA Smart Transmitter realizes the PA standard function block, as the table shown as the table below. Please refer to PROFIBUS PA specification for function block configuration methods.

| Function Block Name | Description |
|---------------------|---|
| Physical Block | Physical block (PB) describes the information of device specific hardware info, recognition info and diagnose info including device bit number, software version, hardware version, installation date, etc. |
| Transducer Block | Transducer block separates the function block from instrument input/output characteristic. It carries out the function of input/output data calibration and linearization, etc, and transfer the data to AI function block via inner channel. |



| | |
|--------------------|---|
| Analog Input Block | Analog input block achieves analog process value via inner channel and process the value, and then provides the right measurement value to master device via bus communication. |
| Totalizer Block | Totalizer block achieves flow instantaneous value via inner channel and cumulates value, and then provides the cumulated value to master device via bus communication. |

7.3 Function Configuration

Please refer to 4.2 Adjusting for PA Smart Transmitter for detailed info about range setting, zero setting, bus address and data recovery of PA smart transmitter.

- **Environment Settings**

- 1) PC with Windows 2000 or Windows XP,
- 2) SIEMENS Step7 configuration software , SIEMENS PDM device management software,
- 3) DP/PA coupler or connector,
- 4) Class 1 master station such as PLC , Class 2 master station such as CP5611 board,
- 5) PA Terminal matcher,
- 6) Standard pressure source.

- **Transducer block parameter configuration**

The transmitter block separates the function block, sensor and special I/O device, it relies on device manufacture to access or control I/O device. Through the access to I/O device, the transducer block can achieve input data or set output data. Generally, the transducer block has the function of linearization, specialization, temperature compensation, control and exchange data,etc. The structure is shown as Figure 7-3.

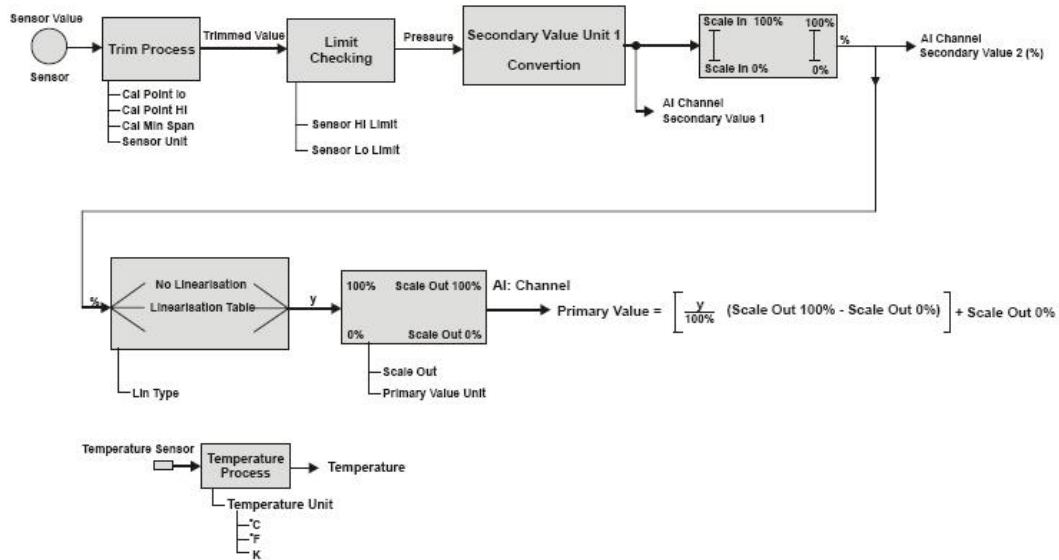

Figure 7-3 Transducer Block Structure

Parameter description as following:

| Parameter | Description |
|---------------------|--|
| CAL_MIN_SPAN | The allowable minimum calibration span is necessary to ensure that calibration is done well, and the two calibration points (highest and lowest) are not too close together. The unit is decided by SENSOR_UNIT. |
| CAL_POINT_HI | When the calibration is at the highest point, it will transfer the pressure signal at the highest point to sensor, and the sensor will write the value to parameter as the highest value at the calibration point. The unit is decided by SENSOR_UNIT. |
| CAL_POINT_LO | When the calibration is at the lowest point, it will transfer the pressure signal at the lowest point to sensor, and the sensor will write the value to parameter as the lowest value at the calibration point. The unit is decided by SENSOR_UNIT. |
| FLOW_LIN_SQRT_POINT | Flow calculation coefficient |
| LIN_TYPE | Linearization type |
| LOW_FLOW_CUT_OFF | Little signal cut value |
| MAX_SENSOR_VALUE | Sensor maximum pressure value, and unit is decided by SENSOR_UNIT. |
| MIN_SENSOR_VALUE | Sensor minimum pressure value, and unit is decided by SENSOR_UNIT. |
| MAX_TEMPERATURE | Sensor maximum temperature value, the unit is Celsius. |
| MIN_TEMPERATURE | It holds the minimum temperature. Sensor minimum temperature value, the unit is Celsius. |



| | |
|-----------------------------|---|
| PRIMARY_VALUE | Transmitter measurement value and status, are available to AI function block. The unit is decided by PRIMARY_VALUE_UNIT. |
| PRIMARY_VALUE_TYPE | Transmitter measurement value type, code as following: 0: Pressure 1: Flow 2: Level 3: Volume 4-127: Reversed > 128: Manufacturer specific By now, it only supports 0 and 1. |
| PRIMARY_VALUE_UNIT | Transmitter measurement value engineering unit code |
| PROCESS_CONNECTION_MATERIAL | Process connection material code |
| PROCESS_CONNECTION_TYPE | Process connection material type code |
| SCALE_IN | Sensor input range, the unit is decided by SECONDARY_VALUE_1_UNIT. |
| SCALE_OUT | Sensor output range, the unit is decided by SECONDARY_VALUE_1_UNIT. |
| SECONDARY_VALUE_1 | This parameter contains the Pressure value and status available to the Function Block. Measurement value and status after modification and unit exchange, are available to AI function block. |
| SECONDARY_VALUE_1_UNIT | SECONDARY_VALUE_1 engineering code |
| SECONDARY_VALUE_2 | Percentage value after input range exchange is available to AI function block. |
| SECONDARY_VALUE_2_UNIT | SECONDARY_VALUE_2 engineering code |
| SENSOR_DIAPHRAGM_MATERIAL | Sensor diaphragm type code |
| SENSOR_FILL_FLUID | Sensor fill-liquid type code |
| SENSOR_HI_LIM | Sensor physical upper range |
| SENSOR_LO_LIM | Sensor physical lower range |
| SENSOR_MAX_STATIC_PRESSURE | Sensor maximum static pressure |
| SENSOR_O_RING_MATERIAL | Type code for O ring between sensor diaphragm and process connection |
| SENSOR_SERIAL_ | Sensor serial number |



| | |
|------------------|---|
| NUMBER | |
| SENSOR_TYPE | Sensor type |
| SENSOR_UNIT | Sensor original data unit |
| SENSOR_VALUE | Sensor original data value |
| TEMPERATURE | Sensor temperature value |
| TEMPERATURE_UNIT | Sensor temperature value unit, now it is Celsius. |
| TRIMMED_VALUE | Pressure value after calibration |

● PROFIBUS Cycle Data Communication Configuration

PROFIBUS DP cycle data communication means Class 1 master station and slave station exchange input and output data in the polling method. The method is unconnected. In each cycle period, Class 1 master station sends data exchange request, and slave station responses the request. Cycle data communication is mainly used for configuration between slave station and PLC master station ,due to the cycle data communication, master station PLC gets input data from slave station real-time, or transfer the output data to the slave station.

PA smart transmitter cycle data communication configuration is the same as PROFIBUS DP slave, we only need to add a coupler or a linker between PA BUS and DP BUS.

PA smart transmitter cyber data comes from AI function block parameter in the device. There are 5 bytes in total, including 4 bytes for pressure value floating-point data and 1 byte status data.

There are 2 standard function blocks, AI and TOT, as well as a vacant function block. If there is only one function block is necessary, you should configure the vacant function block. For example, is only AI function block is necessary, you should configure AI function block and the vacant function block.

For cyber communication, transmitter supports many identifiers. For AI, there are long and short identifiers. For TOT, there are Total, Mode_Total and Set_ Total identifiers, shown as following:

| | | |
|-----|-------------------------------|---------------------|
| AI | Short | 0x94 |
| | Long | 0x42,0x84,0x08,0x05 |
| TOT | Total | 0x41,0x84,0x85 |
| | Total, Mode_Total | 0xC1,0x80,0x84,0x85 |
| | Total, Mode_Total, Set_ Total | 0xC1,0x81,0x84,0x85 |

User may use SIEMENS Step7 for PROFIBUS PA configuration cycle data communication .Open SIMATIC Manager, select PLC master station and create a new project, shown as Figure 7-4.

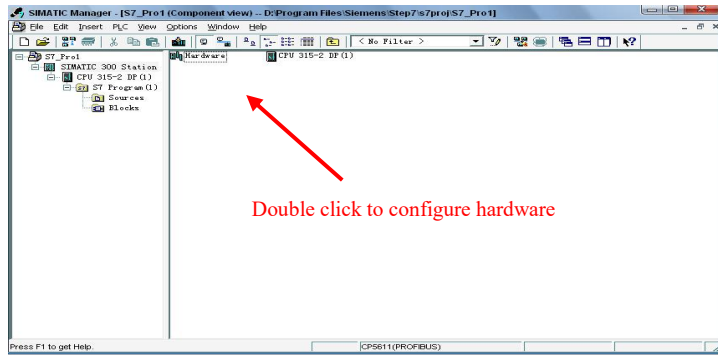

Figure 7-4 Select PLC master station, and create new project

Click hardware twice to open Hardware Configuration in HW Configuration Software. On the menu of Option, select “Install GSD” in Option list, shown as Figure 7-5.

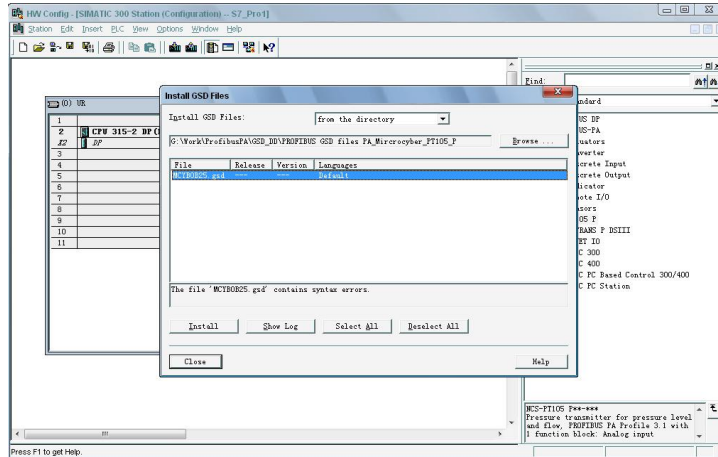

Figure 7-5 Install GSD file

When GSD files is successfully installed, at the right side of HW Configuration software you can see the device we have just installed from PROFIBUS-PA. Using your mouse to select and drag it to PROFIBUS DP BUS, shown as Figure 7-6.

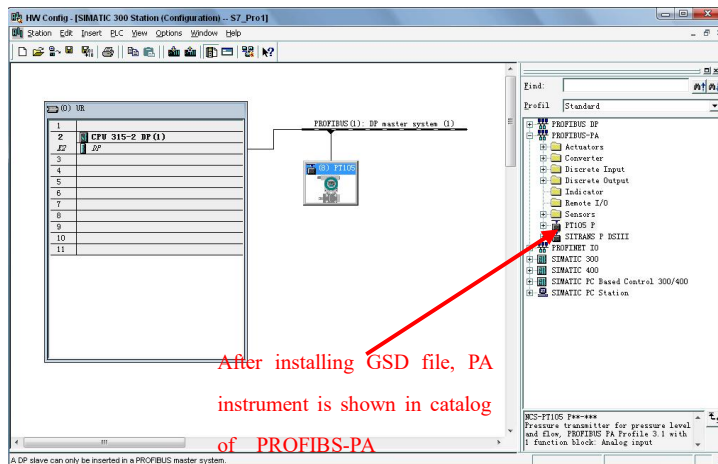

Figure 7-6 Drag PA device to the PROFIBUS DP Bus

Select Download configuration information to PLC master station in the PLC list. It is the last step for the communication configuration between PA instrument and master station cyber data, shown as Figure 7-7.

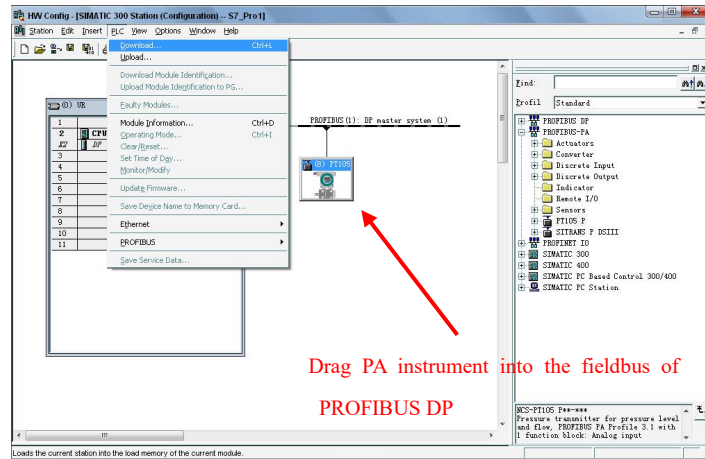

Figure 7-7 Download the configuration to PLC

● **PROFIBUS non-cycle data communication configuration**

PROFIBUS DP non-cycle data communication means facing linking data communication between Class 2 master station and slave station. It is under the circumstance without affection cyber data communication and in the non-cycle period. Non-cycle data is mainly PA function block parameter, recognition and diagnose info, etc. Non-cycle data communication is mainly applied in PA device management, diagnose, recognition, calibration, maintenance, etc.

User may use SIEMENS device management software SIMATIC PDM for non-cycle data communication configuration of PROFIBUS PA transmitters.

Here is an example:

Before the configuration, please add manufacture info.

Find manufacturer.csv file in ...\Siemens\Step7\S7BIN. Add "Microcyber Inc.;Microcyber Inc.;;;Microcyber Inc.;0x016C"

Open SIMATIC PDM Lifelist Software; select Start Scan DP bus from Scan list, shown as Figure 7-8.

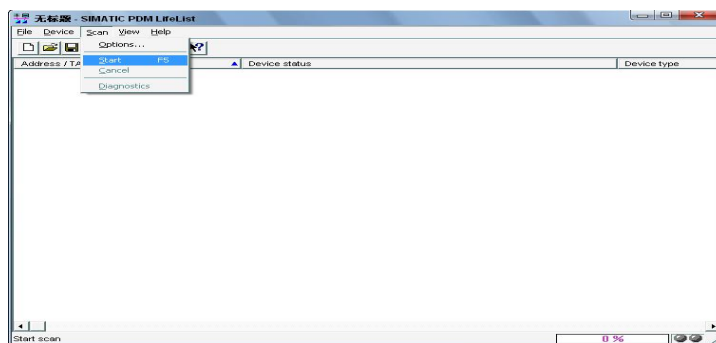

Figure 7-8 Start LifeList

After the bus is scanned, the slave devices in DP bus will be listed, at the same time the device ID and some diagnose info will be shown, shown as Figure 7-9.

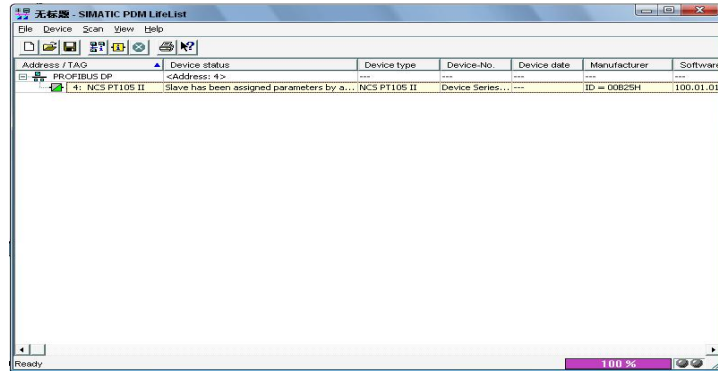

Figure 7-9 Scan DP bus list PA devices

Click PA device twice will start SIMATIC PDM software. According to this software, you can write / read parameter and diagnose PA device. At the popup box, for PA instrument type, choose Device Catalog, to aff GSD file. If it's NCS-PT105 II PA transmitter, you may choose Microcyber Inc\NCS-PT105II shown as figure 7-10.

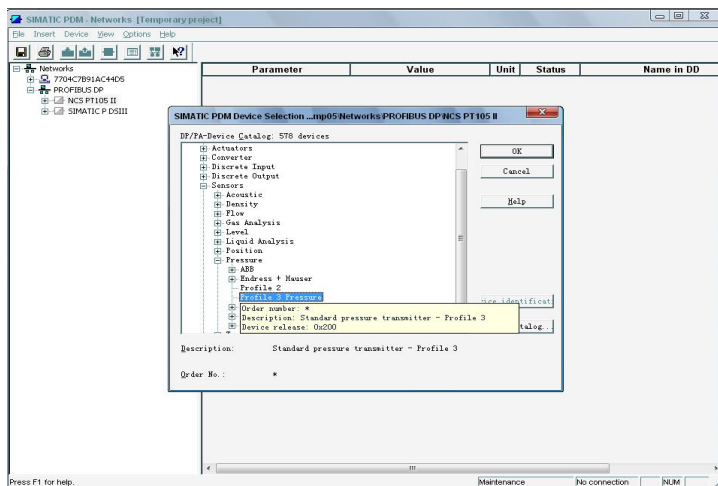

Figure 7-10 Select device type

When device type is selected, click “OK”, now you have finished the configuration. According to the functions of download and upload of PDM software, you can complete writing and reading parameters, shown as figure 7-11 .

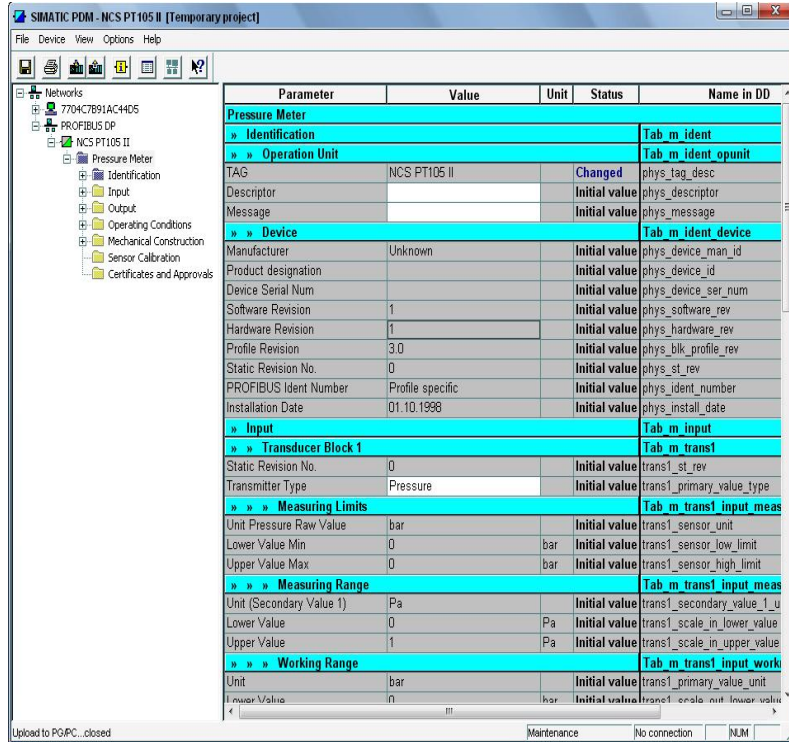

Figure 7-11 Use PDM software to manage device

7.4 Jump-pin Configuration

PA smart transmitter has three hardware jumpers, at present you can use two of them, shown as Figure 7-12 , J3 is non-used.

RST Jumper:Reset jumper will reset the transmitter data back to factory. It is the same as the operation for data back to factory with magnetic bars shown as Chapter 5.4. Please make the transmitter powered off, insert the jumper to RST, and then power the transmitter on, the data will be back to factory data, shown as Figure 7-13.

Attention: After the operation for data back to factory with RST jumper, please turn off instrument power again, pull out the RST jumper, then use the instrument normally. Otherwise if you keep RST jumper like this, when next time you restart the instrument, all data will be back to factory. the configuration info before power off will be lost.

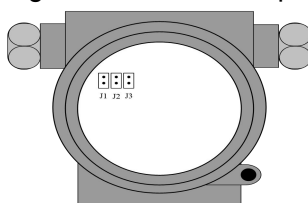

Figure 7-12 PA smart transmitter hardware jumpers

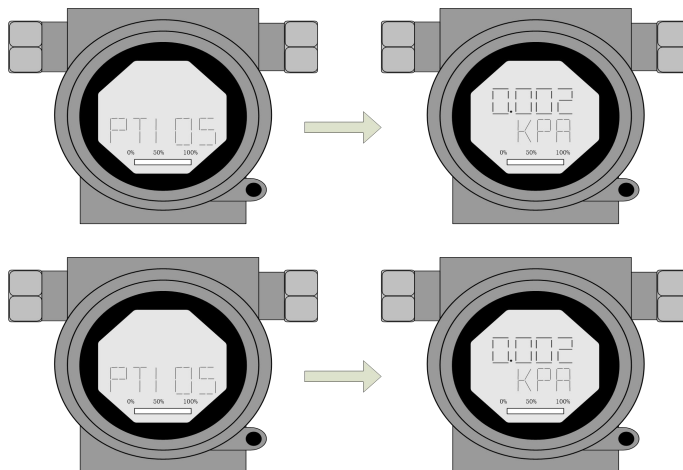

Figure 7-13 PA smart transmitter data back to factory

WP Jumper: Write protection jumper can refuse any write operation for FF smart transmitter, which can avoid the vicious modification for instrument data.



Chapter 8 Maintain

- Simple maintain

| Number | Display | Reason | Methods |
|--------|--|--|--|
| 1 | Output current value is 0 | a. power failure b. wire cutting | a. modify power b. check wire |
| 2 | HART smart transmitter output current value exceeds limit | Failure connection between the sensor and the circuit board. | Check the connection. |
| 3 | HART smart transmitter current fixed on 4mA, add pressure the output, no change. | a. instrument in multi-point mode b. leakage | a. modify slaves address in single mode b. check the connection of gas pipe |
| 4 | Smart transmitter communication failure | a. connection failure b. multi-mode | a. check the wire loop b. check net |

- Daily maintenance: Only clean.
- Failing repair: Please return it back.



Chapter 9 Technical Specifications

9.1 Basic Parameter

| | | |
|------------------------------------|---|--|
| Measure object | liquid、 gas、 stream | |
| Power | 9~32V DC (FF,PA) 9~32V dc (FF, PA Explosion-proof instrument) 11.9~42 V DC (HART) 11.9~30 V DC (HART Explosion-proof instrument) | |
| Output | Analog: 2 wire 4~20mA Digital: HART, FF and PA signal | |
| Load resistant | 0~1500ohm (common) 250~550ohm (with HART) | |
| Insulation | Input and output insulating voltage: 500Vrms (707VDC) | |
| Display | Optional 6 bits digital number or 5 bits characters LCD display | |
| Temperature scale | Work temperature: -40 ~ 85℃ (No display) -30 ~ 70℃ (display) -30 ~ 60℃ (Explosion-proof) Store temperature: -40 ~ 100℃ (No display) -40 ~ 85℃ (display) | |
| Allowed media temperature measured | -40 ℃ ~ 110 ℃ (Type name include 'IC') -40 ℃ ~ 149 ℃ (silicone oil); -40 ℃ ~ 204 ℃ (sylthlem800); -18 ℃ ~ 204 ℃ (inert liquid) -40 ℃ ~ 104 ℃ (others) | |
| Humidity scale | 5%~100%RH | |
| Start time | ≤ 5 seconds | |
| Refresh time | 0.2 seconds | |
| Dump adjusting | Time constant 0~15 seconds | |
| Change of cavity | < 0.16 cm3 | |
| Static pressure limit | SD | Range 3~8: 2000psi (13.8MPa) |
| | SG | Range 3~8: 2000psi (13.8MPa) Range 9: 4500psi (31.0MPa) Range 0: 7500psi (51.7MPa) |



| | | |
|--|----|------------------------------|
| | SA | Range 4~8: 2000psi (13.8MPa) |
| | SH | Range 4~7: 4500psi (31.0MPa) |
| | | |

9.2 Performance Index

| | |
|-------------------------------|--|
| Precision | $\pm 0.075\%$ of Span is for $0.1 \text{ URL} \leq \text{Span} \leq \text{URL}$; $\pm [0.025 + 0.005 \times (\text{URL} / \text{Span})]\%$ of Span is for $\text{Span} < 0.1 \text{ URL}$ |
| Temperature effect | Total effects per 28°C (50°F) change: Span $\geq 0.1 \text{ URL}$: $\pm [0.019\% \text{ URL} + 0.125\% \text{ Span}]$ Span $< 0.1 \text{ URL}$: $\pm [0.025\% \text{ URL} + 0.125\% \text{ Span}]$ |
| Long time stability | In 12 months, $\pm 0.1\%$ of maximum range |
| Static pressure effect | For range 3 $\pm 0.5\% / 13.8\text{Mpa}$ For other ranges $\pm 0.25\%/13.8\text{MPa}$ |
| Location installed effect | The maximum of the zero point movement is 0.24kPa |
| Power effect | $< 0.005\%/V$ of range calibrated |
| Explosion-proof | intrinsically safety Ex ia II C T4 |
| Explosion-proof level | IP65 or IP67 |
| Vibration effect | Meet GB/T 2423-1995 |
| Electromagnetic compatibility | Meet GB/T 17626-1998 (IEC 61326-1: 1997) |

9.3 Physical Properties

| | |
|----------------------------|--|
| Electrical connection | 1/2-14NPT thread in. |
| Process connection | 1/4-18 NPT thread in. |
| Drawing pressure connector | Range 3~5, distance of center is 2.122 inch (53.9mm) Range 6, distance of center is 2.176 inch (55.3mm) Range 7, distance of center is 2.197 inch (55.8mm) Range 8, distance of center is 2.236 inch (56.8mm) Range 9, distance of center is 2.260 inch (57.4mm) Range 0, distance of center is 2.291 inch (58.2mm) |



| | |
|----------------------|--|
| Structural materials | Isolated Membrane and exhaust/outlet valve: 316 stainless steel; Flange and connector: 316 stainless steel; O-ring: fluororubber; Filled liquid: silicon oil or fluorocarbon oil; Bolt: zinc plating carbon steel; (the material above should be selected at order, if has other requirement, please report in advance) Housing: low copper of albronzes; Coating: diene epoxy resin. |
| Height | Display type: 3.5kg No display type: 3.3kg |



Appendix Smart Transmitter Selection

● supplied ○ not supplied

| Model | Type | | | | SG | SA | SD | SH |
|-----------------|--|---------------------|-------------------|---------------|----|----|----|----|
| NCS-PT105 II SG | Gauge Pressure Transmitter | | | | ● | ○ | ○ | ○ |
| NCS-PT105 II SA | Absolute Pressure Transmitter | | | | ○ | ● | ○ | ○ |
| NCS-PT105 II SD | Differential Pressure Transmitter | | | | ○ | ○ | ● | ○ |
| NCS-PT105 II SH | Differential Pressure Transmitter for High Line Pressure | | | | ○ | ○ | ○ | ● |
| Code | Range | | | | SG | SA | SD | SH |
| 3 | 0.075~7.5kPa | | | | ● | ○ | ● | ○ |
| 4 | 0.374~37.4kPa | | | | ● | ● | ● | ● |
| 5 | 1.86~186.8kPa | | | | ● | ● | ● | ● |
| 6 | 6.9~690kPa | | | | ● | ● | ● | ● |
| 7 | 20.68~2068kPa | | | | ● | ● | ● | ● |
| 8 | 68.9~6890kPa | | | | ● | ● | ● | ○ |
| 9 | 206.8~20680kPa | | | | ● | ○ | ○ | ○ |
| 0 | 413.7~41370kPa | | | | ● | ○ | ○ | ○ |
| Code | Type of Communication Protocol | | | | SG | SA | SD | SH |
| H | HART Protocol | | | | ● | ● | ● | ● |
| F | FF Protocol | | | | ● | ● | ● | ● |
| P | PA Protocol | | | | ● | ● | ● | ● |
| WIA | WIA Wireless Protocol | | | | ● | ● | ● | ● |
| Code | Structure Material | | | | SG | SA | SD | SH |
| | Flange | Vent/Drain Valve | Isolated Membrane | Filled Liquid | | | | |
| 22 | 316 stainless | 316 stainless steel | 316 stainless | Silicon oil | ● | ● | ● | ● |
| 32 | 304 stainless | 304 stainless steel | 304 stainless | Silicon oil | ● | ● | ● | ● |
| Option | | | | | | | | |
| Code | Mounting Bracket | | | | SG | SA | SD | SH |
| B1 | 2" Pipe Mounting Bracket (Angle Type) | | | | ● | ● | ● | ● |
| B2 | Plate Mounting Bracket (Angle Type) | | | | ● | ● | ● | ● |
| B3 | 2" Pipe Mounting Bracket (Flat Type) | | | | ● | ● | ● | ● |
| Code | Vent/Drain Valve | | | | SG | SA | SD | SH |
| D1 | side Vent/Drain Valve Top | | | | ● | ● | ● | ● |
| D2 | side Vent/Drain Valve Bottom | | | | ● | ● | ● | ● |



| Code | Process Connector | SG | SA | SD | SH |
|------|--|----|----|----|----|
| D42 | 316SST, Symbol 2□ | ● | ● | ● | ● |
| D40 | 304SST, Symbol 3□ | ● | ● | ● | ● |
| Code | Drawing Pressure Connector | SG | SA | SD | SH |
| C22 | 1/2—14NPT, pressing sleeve seal, 316 stainless steel | ● | ● | ● | ○ |
| C23 | 1/2—14NPT, pressing sleeve seal, 304 stainless steel | ● | ● | ● | ○ |
| C32 | 1/4—18NPT, pressing sleeve seal, 316 stainless steel | ● | ● | ● | ○ |
| C33 | 1/4—18NPT, pressing sleeve seal, 304 stainless steel | ● | ● | ● | ○ |
| C42 | 1/2—14NPT, welding seal, 316 stainless steel | ● | ● | ● | ○ |
| C43 | 1/2—14NPT, welding seal, 304 stainless steel | ● | ● | ● | ○ |
| C52 | 1/4—18NPT, welding seal, 316 stainless steel | ● | ● | ● | ○ |
| C53 | 1/4—18NPT, welding seal, 304 stainless steel | ● | ● | ● | ○ |
| C62 | T type, M20, welding seal, 316 stainless steel | ● | ● | ● | ○ |
| C63 | T type, M20, welding seal, 304 stainless steel | ● | ● | ● | ○ |
| Code | Indicator | SG | SA | SD | SH |
| M5 | LCD Indicator | ● | ● | ● | ● |
| Code | Type of Explosionproof | SG | SA | SD | SH |
| IC | Ex ia IIC T4 | ● | ● | ● | ● |
| IA | Ex ia IIC T6 | ● | ● | ● | ● |
| DC | Ex d IIC T4 | ● | ● | ● | ● |
| DA | Ex d IIC T6 | ● | ● | ● | ● |
| Code | Material of O-ring | SG | SA | SD | SH |
| W2 | Butadiene-arylonitrile rubber | ● | ● | ● | ● |
| W3 | Ethylene propylene | ● | ● | ● | ● |
| Code | Material of Bolt | SG | SA | SD | SH |
| L1 | 1Cr18Ni9 | ● | ● | ● | ● |
| L3 | 42CrMo | ● | ● | ● | ● |
| Code | Valve Manifold | SG | SA | SD | SH |
| T2 | 3-valve, 304 Stainless steel | ○ | ○ | ● | ● |
| T3 | 3-valve, 316 Stainless steel | ○ | ○ | ● | ● |
| T4 | 5-valve, 304 Stainless steel | ○ | ○ | ● | ● |
| T5 | 5-valve, 316 Stainless steel | ○ | ○ | ● | ● |



MICROCYBER

YOUR FIELDBUS EXPERT

CONTACT INFORMATION

**Address: 17-8 Wensu Street, Hunnan New District, Shenyang,
China**

Website: <http://www.microcyber-fieldbus.com>

Phone: +86-24-31217278/+86-24-31217280

Fax: +86-24-31217338

Email: guo.ruibing@microcyber.cn